

RADITEK SATCOM GROUP

SHORT FORM CATALOG



RADITEK
SATCOM

1. Satcom. We manufacture and supply the most advanced modems, to support internet and E1 Backhaul, Scada and STAR and MESH networks, for example. RADITEK can supply up to 400W 1+1 SSPA C band (inside), and Ku Band (outside) with L band or 70/140 MHz IF, BUCs (Block Upconverters) and Transceivers, LNAs and LNBs (1+1) for example in the corresponding bands.

2. IOTM (Internet on the Move) and other antennas. We have one of the most advanced low form factor/phased array IOTM solutions for Ku and soon Ka band. Our IP/DAMA modem is ideal for this too, as it will remain locked when TDMA based modems are continually losing lock. The unit is suitable for any vehicle boat and train.

3. SCPC/DAMA MODEM. for full switched Internet networking. Supports UPC (Uplink power Control) to 8PSK, TPC, with 16QAM and LDPC coming soon. With optional NMS control, allows full DAMA (Demand Assigned Multiple Access), ABOD (Automatic Bandwidth On Demand), and multiple, single hop MESH and/or STAR networks. Low cost, easily upgradable hub, with no obsolescence. The RISN-1000-BRT modem, for example is also a full internet router, and can address up to 16 x private IP addresses/LANs at once, across the satellite.,

4. FULL SCPC MODEM. with extensive internal analysis capability with E1/T1 and IP. Can support to over 30Mbps, 4 x E1, Internet 16QAM, carrier in carrier, and LDPC or TPC etc. Internal analysis tools perform real time BER tests, interference analysis and drop and insert (E(0)s in an E1.

5. TWTAs(Travelling Wave Tube amplifiers. Satcom C, X and Ku bands to 750W, 1+1 redundancy options and a full range of Broadband, to octave bandwidth, within 1- 40GHz to several KWs, CW and Pulse.

6. RF Over Fiber, 50MHz - 20GHz Fiber Optic transmission is the most efficient means to transmit RF signals over long distance.

[SEE OUR TELECOM CATALOG](#)

WORLD HQ: 1702L Meridian Ave. Suite 127, San Jose, Ca 95125, U.S.A.

Tel: (408) 266-7404

FAX: (408) 266-4483

WEB: www.raditek.com

E-mail: sales@raditek.com

Introduction

RADITEK was founded in 1993

- ❖ Started as a manufacturer of isolators
 - High power coax, drop-in, microstrip and waveguide to 150 GHz.
- ❖ Included Oscillators:
 - DROs, Phase locked DROs
 - Crystal: OCXOs, VCXOs, VCTCXOs etc
 - Synthesizers, VCOs etc
 - Most recent YIG oscillators to >30GHz
- ❖ Combiners and couplers
 - Coax, multi way, couplers etc
- ❖ Filters
 - Compline, SAW, waveguide, diplexers etc
- ❖ Subsystems=TELECOM
 - SSPA Amplifiers, TWTAs. High power, low noise and wide band Pulsed/CW etc...
- ❖ Advanced VRAX OFDM wireless HD-video link
- ❖ Point to Point radio and WiMax 5.8GHz etc.
- ❖ Satcom: BUCs, Transceivers, Advanced Modems
 - Advanced antennas-incl. On the Move -Internet



Introduction

RADITEK's unique IP based, network modem:

- ❖ *Designed for IP packet routing within a satellite network that connects to Ethernet networks at every site, including gateways, hubs and remotes.*
- ❖ *Provides direct, seamless IP (Internet Protocol) connectivity for computer LANS, voice and video to and from any remote.*
- ❖ *Switched links can be set up on demand*
- ❖ *Can be configured as a (always single hop) Point to Point (MESH) or Multipoint (STAR) Ideal for mobile Internet:*



- ❖ *Gives 2-3 dB more coding gain than other types of coding using 3D TPC and LDPC coding*
- ❖ *Means lower cost BUCs possible (as lower power)*
- ❖ *Improved Quality of Service (QoS) for a given Eb/No*
- ❖ *Lowest cost, as uses embedded in FPGA/ASIC*
- ❖ *For all data rates to 8Mbps (20 and 30 Mbps modems coming soon)*
- ❖ *Maximizes RADITEK's satellite bandwidth efficiency (lowers OPEX)*
- ❖ *Combined with RADITEK's BOD/DAMA/SCPC with automatic uplink power control beats all competition! For both CAPEX AND OPEX!*

Next see a Modem and a HUB unit (supports to 32 remotes):-

MOST ADVANCED IP Based Satellite Network Solution

Network Control display showing total network and status by color.

GUI Network display example shows an Internet hub in London, remotes all over Africa etc. **SCPC/DAMA gives up to 98% satellite efficiency.**

Allows secure, Interactive Internet access, DVB-S2 Rx option available To 8Mbps data rate (2 way) with low cost remote and hub. Minimal overhead SCPC/DAMA with:



- **ADVANCED Switched, IPSatellite DAMA Network**
- **DAMA (Demand Assigned Multiple Access)**
- **BOD (Bandwidth on Demand)**
- **AUPC (Automatic Uplink Power Control)**
~>30% more efficient than TDMA
- **Most advanced Turbo Product Code, LDPC soon**
- **To 3dB lower Eb/No than many others.**
- **Means lower cost BUCs or smaller antennas.**
- **Ideal for Internet on the MOVE Disaster Recovery applications etc**
- **Ideal for lowest cost SCADA**
- **DVB-S2 with SCPC/DAMA/BOD return option**
- **To ~10µs (10E-8) network timing accuracy**

RISN-99VRT advanced remote SAT terminal with Internet router 8Mbps up and downlink



RISN-88VRT lowest cost Satcom Terminal with built-in Internet router To 2Mbps uplink, 8Mbps downlink from Hub

- Designed for IP packet routing within any frequency satellite network that connects to Ethernet networks at every site, including to 16 gateways, hubs and remotes per modem.
- **Provides Direct, Seamless IP (Internet Protocol) connectivity for computer LANS, voice and video to and from any remote.**
- Can be configured as Point to Point (MESH) &/or Multipoint (STAR) in separate or same network.
- **Can also be a stand alone modem, for Point to Point full time SCPC with 70MHz or L band IF.**
- Raditek's full line of C, X, Ku and Ka band low cost BUCs and phase locked LNBS.

- RJ45 internet access and an internet router included in every remote modem-to 16 dedicated IP addresses
- **Usually TDMA is bad choice for <10Mbps, has timing issues , needs excessive ~>30% overhead and RCS especially has poor ~50% satellite efficiency!**
- Use one or more gateway hubs to one or multiple satellites.
- **To be up to half the cost of the "others" with no limit to number of users, as long as satellite BW is there.**
- Efficient Turbo codes can halve the necessary BUC transmit power, compared to less efficient RS/Viterbi convolutional codes etc. low latency LDPC can further improve to ~2dB more.

MOST ADVANCED IP Based Satellite Network Solution

Applications where our SCPC/DAMA/BOD approach is the best solution by far, compared to TDM/TDMA products!

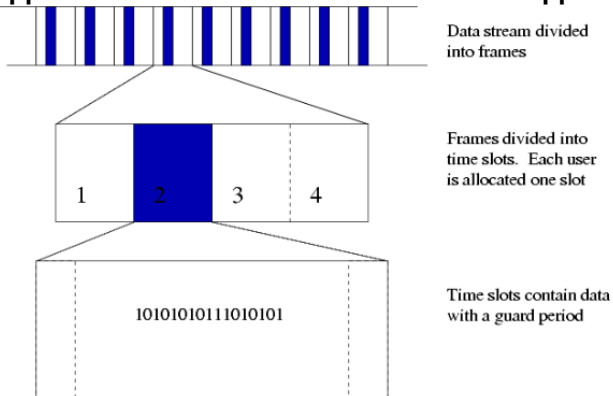

SCADA: TDM outbound via a DVB-S2 is efficient for higher data rates and can have low cost demods (DVB-S is very basic and does not even have Turbo coding), although the hub is expensive. TDMA/RCS return is very inefficient on the satellite, requiring excessive overhead due to guard band and expensive hub (TDMA demodulator is very expensive at the HUB). High network synchronization is also needed, using GPS or OCXO. There is a **TDMA low end data rate of 256Kbps**, whereas **RADSAT** can support **16Kbps** channels for **SCADA**, for example. Using **RADSAT**'s transmit only remotes and low cost hub (Receive only), extremely low cost solutions are possible, and each remote can reuse a very small satellite bandwidth for lowest possible usage cost.

We offer DVB-S2 for higher data rates and offer SCPC/DAMA return (instead of costly and inefficient TDMA/RCS).

INTERNET NETWORK: One installation in Africa, for example, has a problem of accessing a reliable Internet POP. The DVB/TDMA solution would have the HUB, placed somewhere in Africa but also need some kind of expensive broadband link to the internet access point in UK..-adds a lot of cost and network vulnerability. **RADSAT**'s approach would be to still have the service provider's hub with the NMCS in Africa, but using a **RADSAT dual star** configuration, the POP in UK or wherever, would operate as a **gateway HUB**, controlled from the Africa HUB's NMCS. Internet traffic would be to and from the UK based gateway hub directly, without the need to go through the Africa hub at all, saving a double satellite hop with the associated 2 x satellite cost, with **no need for a high speed link between UK and Africa!** So **RADSAT** again is the obvious choice.

On the move, Mobile Internet and Disaster recovery applications: Whether for INTERNET ACCESS **DISASTER RECOVER** or Police/Military **mobile application**, combining the **RADSAT** modems, with our very advanced low profile, Motion Stabilized **Phased array antenna POD (with a 20 or 40W Ku band BUC, for example, and LNB)**, mounted on the roof of a HUMMER, train, cruise ship, or boat!-easy to install for **Internet on the Move applications**. **No big antenna Radome sticking up, and TDMA cannot be used for this application PERIOD!**

Some customer questions:

Do you support IEEE1588 network synchronizing algorithm for Backhaul applications? Ans: **YES!** We would add an additional 1588 server at the HUB for the whole network. The customer would provide the 1588 compliant BTS. The 1588 implementation is transparent on our network!

Do you offer any kind of Carrier in Carrier for even better network efficiency? Ans: **YES our SCPC modem has this option, called SIMU-Carrier™**, this can save a lot of OPEX when the user owns their own Satellite, or they are not charged for EXCESS POWER as well as bandwidth, **otherwise any OPEX savings can be negligible.**

As the bandwidth savings will be erased by the extra satellite carrier implementation power cost. We have experience using this and there is usually up to 3 dB increase in power necessary (on the satellite), so although the operating bandwidth can be reduced by up to 50% (typically it is much lower than that), the bandwidth reduction cost savings on the satellite results in a **~3dB power increase**, meaning close to **net zero cost reduction**. So we advise you to consider this very carefully.

NOTE: This is a general answer, applicable to anyone else's CIC or similar product, not just ours'.

IP Based Intelligent Satellite Network Solution Router Modem, Smart IP Switched Mini Hub or Remote Terminal RISN-1000-BRT-j8

Mini Hub for small network / stand alone system, NCMS, working to RISN-99VRT



- In the [MESH Network Mode](#) it operates as a multi-channel terminal/Hub and Internet router
- In the [SCPC/STAR Mode](#), it allows 16Kbps to 8Mbps traffic to go directly from one remote to another, with a single hop. It beats TDMA terminals in every way: lower latency and highest efficiency.

- In the [Stand Alone Mode](#), it operates as a high rate, pre-assigned multiple access (PAMA) SCPC/MCPC modem, with an embedded router.

Applications:

- Mini-Hub for up to 8 channels
- 4 channels standard
- Additional 4 channels option
- Mesh Voice Connections
- MCPC Videoconference
- Remote Database Replication
- Internet Access,
- DVB-SCPC
- P-to-P and P-to-Surveillance
- SCADA
- COTM (On-the-Move) COTP
- Emergency Response

Advantages:

- Mesh Connection mode
- Multiple/Double Star Network
- Lower BUC power/Cost
- Highest Channel Efficiency
- Fast Response Time
- Supports DVB-S/S2 carriers

Features:

- MULTIPLE channel support
- Data Rates up to 8 Mbps
- Satellite IP router
- Automatic Channel Switching
- Single or Multiple Star Network
- Satellite IP Router
- Standalone or Network Mode
- Web based GUI
- Multicasting
- Graphical Traffic Display

RADITEK RISN-1000BRT™ is especially suitable for voice and multicasting VIDEO applications. They are the most flexible, with the widest range of data rates from 16 Kbps to 8 Mbps in SCPC mode. As it uses no TDMA-like overhead for multiplexing, and superior coding, smaller BUC power and antenna can be used.

It also means faster response time and faster carrier acquisition in real time applications.

In the DVB-SCPC mode, a highly efficient SCPC/MCPC return channel is used from MESH networks, plus broad band access.

RADITEK's multi-channel modems, used at the hub, provides the most cost efficient point-to-multipoint SCPC connections.

The terminals have the option to upgrade their SCPC network to full DAMA (Demand Assigned Multiple Access), BOD (Bandwidth on Demand), and support of intelligent network traffic switching by adding their advanced NMCS (Network Management and Control Subsystem) to the network and Intelligent traffic switching-i.e. ability to configure structure and dynamic routing ability.

It transmits a single carrier, sized to support the single site traffic, instead of sharing a small part of a big TDMA carrier (like DVB-S/S2).

IP Based Intelligent Satellite Network Solution
Router Modem, Smart IP Switched Mini Hub or Remote Terminal
RISN-1000-BRT-j8

Mini Hub for small network / stand alone system, NCMS, working to RISN-99VRT



Service Applications

High performance, broadband IP based..multiple 2-way for mesh.. multi-STAR network VSAT links

ACCESS Technology

Composite TDM Outbound Carrier using Packet Division Multiple Access (PDMA).
Contention Access Slotted Aloha Inbound (CSC-IB) to initiate DAMA (Demand Assigned Multiple Access).
SCPC / MCPC Inbound Carrier for IP traffic services
Bandwidth-On-Demand (BOD) automatic Inbound Carrier rate to match real time IP traffic demands

Internet routing

Intranet/Internet, Multicast, TCP/HTTP acceleration
DNS Caching
Standard & Customized QoS traffic Prioritization Protocols:
TCP, UDP, RIP, ARP, DHCP, ICMP, IGMP, TELNET, PPP, FTP, HTTP, SMTP, SNMP

Outbound Carrier

Proprietary TDM with PDMA, or SCPC/MCPC
QPSK Modulation
Turbo Product Code FEC at ~1/2, ~3/4, ~7/8 Rates
Carrier Data Rate 16 to 8,192 Kbps, 1.20 or 1.30 Symbol Rate Carrier Spacing Options

Inbound Carrier (Inbound Carrier rate adaptability to match actual site traffic)

Slotted Aloha at 24~48 Kbps for initial network entry and DAMA SCPC/MCPC with BOD for IP traffic.
Turbo Product Code FEC available at: ~1/2, ~3/4 and ~7/8 Rates.
Carrier Data Rate: 16Kbps to 8.192 Mbps
Real Time Demand, 1.20 or 1.30 Symbol Rate Carrier Spacing Options

ODU Interface

Transmit: 950-1850 MHz L-band with 2.5 KHz steps; +24VDC @ 2.7A and 10 MHz Reference @ 0 dBm, Type "F" (f)
Coaxial connector, 75Ω, Level: -45 to -0 dBm in 1 dB steps.
Receive: 950-1850 MHz L-band with 2.5 KHz steps; +24 VDC @ 0.3A and 10 MHz Reference @ 0 dBm, Type "F"
(f)Coaxial connector, Type "F", 75 Ω, Level: -75 to -35 dBm

Mechanical & Environmental

RJ-45, 10/100 Base T Ethernet Interface
RS-232 Asynchronous Serial Interface to ACU
AC Power, IEC-320 Interface 110-240 VAC (47-63Hz) 100 watts, 48VDC @ 3.5A (option)
Dimensions: 43 x 250 x 310 mm (1.7"x9.84"x12.2") Desktop/Rack, Weight: 2.2 Kg (4.84 Lbs)
Operational: 0 to +45°C, Storage: -30 to +70°C
Humidity: Up to 95 %, non-condensing

Options: ► 3D Turbo Product Code ► AES Encryption ► FSK Smart ODU M&C ► High Stability Clock

IP Based Intelligent Satellite Network Solution

RISNS-HUB-BT - Base Terminal, Smart IP Switched, Router Modem, 4 Slot Chassis

4 slot Chassis: each slot takes up to 4x2 way channels, or 8x1way channels



The RISN-HUB is a hub based modem, mountable in an industrial 2U, 19 inch standard rack. Supporting SCPC, MCPC to VSAT networking. It uses super efficient Turbo Product Code for data rates from 16Kbps to 8192Kbps. It can Support up to four MCPC carriers and 16 receive channels or up to 32 demodulators. Space savings capable to directly replace 32 X 1U SCPC modems. With standard features including, but not limited to Header Compression, SNMP, and embedded router, this unit plays an important role in supporting a very wide range of applications.

Each Unit comes with a LCD front panel with controls for local monitor and control, for terminal operation and status. The terminal can be configured with one to many transmitter and receivers, with either 70MHz or L-band (950 ~ 1450 MHz) IFs. An RJ-45 connector supports 10/100 Base T and an optional RS-530 synchronous serial interface and G.703 E1 interface are available.

Feature Highlights:

- Turbo Product Code (TPC)
- Forward Error Connection (FEC)
- Encryption
- High-speed interface

Highlights:

- Avoids limitations by competing VSAT Products
- Optimized for outbound traffic requirements
- Reduced, recurring bandwidth requirements without compromising peak traffic demand
- Designed to implement low cost Star and/or Mesh communications

Modem/Router Cards

Modulation/Demodulation
Forward Error Correction

FEC Rates

IF Output Frequency

IF Input Frequency

Transmit Level

Receive Level

Impedance

Information Data Rates

Modem/Router Card types

Number of Cards Supported

Modem Carrier Spacing

Coherent BPSK /QPSK /8PSK with differential encoding

Concatenated Convolutional / Reed Solomon & Turbo Product Code (TPC)

1/2, 3/4, or 7/8 rate Concatenated
and (16, 11) X (32, 26) R=0.559 TPC
and (64, 57) X (32, 26) R=0.718 TPC
and (64, 57) X (64, 57) R=0.793 TPC

70±18 MHz IF with 2.5 KHz step size

70±18 MHz IF with 2.5 KHz step size

-15dBm to -45dBm with 0.5dB step size, 10dB (15dB optional) of additional power for uplink power control.

-30 to -60 dBm @ 70±18 MHz

50 ohms BNC

Variable 16 to 8192 KBs

Single TX Single RX (STSR)

Single TX Quad RX (STQR)

Quad RX Only (QRO)

Eight RX Only (8RO)

Four for "PRO" chassis

1.20 or 1.30 times the Symbol Rate for
< 0.20 dB degradation

IP Based Intelligent Satellite Network Solution

RISNS-HUB-BT - Base Terminal, Smart IP Switched, Router Modem, 4 Slot Chassis

4 slot Chassis: each slot takes up to 4x2 way channels, or 8x1way channels

DATA/ROUTER

Physical Interface	DB-25 Pin synchronous& RJ-45 for Ethernet
Acquisition Time	Typically 2 sec, including satellite delay at 32 KBs Data rate
Serial Data Interface	RS-530 Standard; RS-422, RS-449, or V.35 using ribbon cable adapter
Ethernet Interface	10/100 Base-T, IEEE802.3
Synchronous Interface	Type DCE
Clocking Buffer	0 Kbit to 1024 Kbit; optional and selectable via software control
Ethernet Protocols	TCP UDP RIP ARP DHCP ICMP IGMP Telnet PPP FTP HTTP SMTP SNMP

ENVIRONMENTAL CONDITIONS

Standard Operating Indoor Equipment Temperature	+5° to +40°C
Storage Temperature	-10° to +70°C

DIMENSION AND POWER

Dimensions "PRO" Chassis	3.5" H X 19" W X 17.25" D
Power	115 VAC - 240 VAC, 50Hz or 60Hz, 30 Watts per Modem/Router card

BIT ERROR RATE PERFORMANCE (LINEAR CHANNEL at IF)

Configuration	BER	Ebi/No for 1/2	Ebi/No for 3/4	Ebi/No for 7/8
BPSK/QPSK	1X10-6	4.1 dB	5.6 dB	6.8 dB
Concatenated, Convolutional, and RS FEC	1X10-8	4.5 dB	6.0 dB	7.3 dB
	1X10-10	4.8 dB	6.3 dB	8.0 dB

Turbo Product Code Rate	BER	Ebi/No for BPSK	Ebi/No for QPSK	Ebi/No for 8PSK
(16, 11) X (32, 26) R=0.559 TPC	1 x 10-6	3.5	3.5	7.0
	1 x 10-8	4.1	4.1	7.5
	1 x 10-9	4.5	4.5	8.0
(64, 57) X (32, 26) R=0.718 TPC	1 x 10-6	3.5	3.5	7.0
	1 x 10-8	4.1	4.1	7.5
	1 x 10-9	4.5	4.5	8.0
(64, 57) X (64, 57) R=0.793 TPC	1 x 10-6	3.5	3.5	7.0
	1 x 10-8	4.1	4.1	7.5
	1 x 10-9	4.5	4.5	8.0

(Where Ebi/No is referenced to information rate)

SCPC Satellite Modem, (5-155 Mbps), (70M/140M/L band- IFs) RMOD-SCPC-multi IF-p3

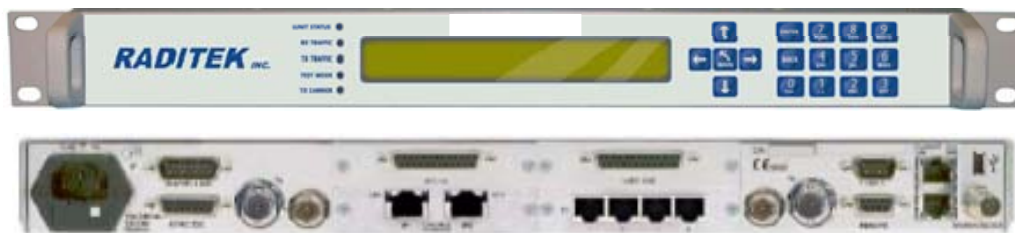

RADITEK's new multiband IF, SCPC modem embodies a new concept in SCPC satellite modem technology - a **flexible software-defined modem**.

The **flexible hardware platform** provides 70/140MHz and L-band operation in one unit. Its powerful processor makes it ideal for handling IP traffic, the modem can be fitted with virtually any standard type of terrestrial interface and options will allow it to operate at data rates up to 155Mbps.

Flexible pricing is achieved by enabling only the features you need at "the" time.

Futureproofing (ideal for future upgrade from 70MHz to L-Band), is assured by convenient software activated upgrades.

Advanced Bandwidth-Efficient Features

This SCPC modem supports the most powerful SCPC bandwidth-saving, except for of our IP networking family of modem, which is the ultimate.

- **Simu-Carrier™** shares the same transmit and receive frequency reducing satellite bandwidth by up to (in some cases) a full 50% at the expense of some Transmit power. This allows perfect transponder loading and possible cost savings, especially in the case where there is no extra satellite Tx power penalty/cost .
- **Low-latency LDPC** has been designed for Eb/No extending applications (1-2 dB better than TPC)
- **DVB-S2** option is also available.
- Advanced bandwidth-saving IP features include acceleration and header and payload compression.

Features

- Multi IF band support: (70M, 140M and L-band)
 - Data rates to 155Mbps
 - DVB-S2, LDPC, TPC FEC options
 - Terrestrial interface options including Ethernet, EIA-530, G.703, OC-3, STM-1, LVDS, ASI, HSSI
 - Modulation up to 64QAM
 - Simu-Carrier™ option
 - Uplink Power control
 - Signal-under-carrier interference detection tool
 - Built-in spectrum and constellation monitors tool
 - IPv6 compliant
 - Interoperable with other Raditek SCPC modems
 - Feature-based pricing
- Software upgradeable for many options.

Applications include:

- IP trunking
- Mobile backhaul
- Maritime communications
- Corporate networking
- Disaster recovery
- Satellite news gathering
- G.703 backhaul
- Advanced IP feature set options,
 - including TCP
 - HTTP acceleration,
 - Compression,
 - Routing, bridging, encryption
 - traffic shaping
 - ACM

SCPC Satellite Modem(5-155 Mbps), (70-140MHz/L), IF RMOD-SCPC-multi IF-p3

Specifications	
Frequency	IF: 50 to 90MHz & 100 to 180MHz (resolution 100Hz) (BNC connector) L-band: 950 to 2050MHz (resolution 100Hz) (N-type connector)
Data Rate	DVB-S2: 50kbps to 155Mbps LDPC: 4.8kbps to 100Mbps TPC: 4.8kbps to 60Mbps 1bps resolution Operation to 2,048kbps provided as standard; Extension Options to 5Mbps, 10Mbps, 25Mbps, 60Mbps, 100Mbps and 155Mbps
Symbol Rate	DVB-S2: 100ksps to 45Msps Non-DVB-S2: 9.6ksps to 40Msps
Operating Modes	DVB-S2 (EN 302 307) option Closed Network (+ ESC) (IESS-315) IBS/IDR (IESS-308/309/310/314) options
Scrambling	DVB-S2: as per EN 302 307 IBS: Synchronized to framing per IESS-309 Closed Network + ESC: Synchronized to ESC overhead
Impedance	IF: 50Ω/75Ω L-band: 50Ω
Return Loss	IF: 18dB typical L-band: 14dB typical
Frequency Reference Stability	Ageing <4E-8/yr
External Reference	Clocking only: 1 to 10MHz, 1kHz steps Clocking and RF frequency: 10MHz, 0dBm±1dB
Redundancy	Can be operated in standalone, 1:1 or 1:N redundancy configuration

Traffic Interfaces	
Base modem (standard):	Ethernet (10/100/1000 BaseT) IP traffic on RJ45 with processing capability of 100,000 packets per second
Traffic options:	EIA-530 (RS422, X.21, V.35 and RS232 on 25-pin D-type female) G.703 (balanced on RJ-45; unbalanced 75Ω BNC female) Quad E1 G.703 (balanced RJ45) Quad ASI (75Ω BNC) STM-1/OC-3/Optical Gigabit Ethernet (small form-factor pluggable module) Serial LVDS (25-pin D-type female) HSSI (50-pin HD SCSI-2 connector)
RadMux option:	generates a single carrier from any mixture of G.703, IP and EIA-530 traffic (requires Quad E1 option)

Modulator	
Output Power	IF: 0 to -25dBm (0.1dB steps) L-band: 0 to -30dBm (0.1dB steps)
Output Power Stability	±0.5dB, 0°C to 50°C
Transmit Filter Roll-off	20%, 25%, 35%
Phase Accuracy	±2° maximum
Amplitude Accuracy	±0.2dB maximum
Carrier Suppression	-30dBc minimum
Output Phase Noise	As IESS-316, nominally 3dB better
Harmonics	Better than -55dBc/ 4kHz in band
Spurious	Better than -55dBc/ 4kHz in band
Transmit On/Off Ratio	55dB minimum

Demodulator	
Input Range	IF minimum: -115+10 log (symbol rate) L-band minimum: -130+10 log (symbol rate) IF/L-band maximum: -80+10 log (symbol rate)
Maximum Composite Signal	+10dBm
Wanted-to-composite Level	IF: -94+10 log (symbol rate) L-band: -102+10 log (symbol rate)
Frequency Sweep Width	±1kHz to ±32kHz up to 10 Msps (1kHz steps) ±10kHz to ±250kHz above 10 Msps (10kHz steps)
Acquisition Threshold	<5dB Es/No QPSK
Acquisition Time	Dependent on FEC, data rate and sweep width (at 9.6kbps, less than 1s at 6dB Es/No QPSK; at 10Mbps, less than 100ms at 6dB Es/No QPSK)
Clock Tracking Range	±100ppm minimum
Receive Filter Roll-off	20%, 25%, 35%
Performance Monitoring	Eb/No (range 0-15dB, ±0.2dB) Frequency offset (100Hz resolution) Receive signal level Buffer fill status
AGC Output	Buffered direct AGC output for antenna tracking, etc.

SCPC Satellite Modem(5-155 Mbps), (70-140MHz/L), IF RMOD-SCPC-multi IF-p3

Forward Error Correction	
Modulation	1. DVB-S2 (Option): QPSK, 8PSK, 16APSK 2a. Non-DVB-S2: BPSK, QPSK, OQPSK 2b. plus options for: 8PSK, 16QAM, 2c. Low Latency LDPC: 8QAM, 16APSK, 32APSK, 64QAM
FEC	1. DVB-S2 (LDPC/BCH) option: QPSK: 1/4, 1/3, 2/5, 1/2, 3/5, 2/3, 3/4, 4/5, 5/6, 8/9, 9/10 8PSK: 3/5, 2/3, 3/4, 5/6, 8/9, 9/10 16APSK: 2/3, 3/4, 4/5, 5/6, 8/9, 9/10 2. Non-DVB-S2: Note BPSK and (O)QPSK provided as standard ; other modulations are options 3. Low-Latency LDPC option: BPSK: 0.499 (O)QPSK: 0.532, 0.639, 0.710, 0.798 8PSK/8QAM: 0.639, 0.710, 0.778 16APSK/16QAM: 0.726, 0.778, 0.828, 0.851 32APSK: 0.778, 0.828, 0.886, 0.938 64QAM: 0.828, 0.886, 0.938, 0.960 4. TPC option: BPSK: 5/16, 21/44, 2/3, 3/4, 0.493, 7/8, Rate 7/8 de facto, 0.789, (O)QPSK: 5/16, 21/44, 2/3, 3/4, 0.493 7/8, 7/8 de facto, 0.789, 0.93 8PSK: 3/4 de facto, 7/8 de facto, 0.93 16QAM: 3/4 de facto, 7/8 de facto, 0.93 5. Viterbi: BPSK/(O)QPSK 1/2, 3/4, 7/8 6. TCM option: 8PSK 2/3 7. Sequential option: BPSK/(O)QPSK 1/2, 3/4, 7/8 8. Reed-Solomon: Outer codec available with Viterbi and TCM

Header Compression Option	Robust Header Compression to RFC 3095. Reduces Ethernet/IP/UDP/ TCP/RTP header sizes typically by 90%. 1-way packet processing limit: 60,000 pps; 2-way limit: 45,000 pps. Includes Ethernet header compression (compresses 14-byte Ethernet frame to typically one byte)
Payload Compression Option	Uses Deflate algorithm (RFC 1951) to compress all TCP/IP packets (TCP and UDP), typically resulting in compression of payloads by 50%
Traffic Shaping Option	Provides guaranteed throughput levels for IP streams, using Committed Information Rate and Burst Information Rate settings. Stream differentiation is by IP address, IEEE 802.1p priority class, Diffserv DSCP class or MPLS EXP field
Encryption Option	Encrypts all IP traffic using AES with 256-bit keys
IPv6	Provided as standard. Dual IPV4/ IPV6 TCP/IP stack allowing use of both IPV4 and IPV6 addresses for bridging and routing of traffic
VLAN Support	IEEE 802.1q VLAN support (standard) IEEE 802.1p Quality of Service (packet prioritization) using strict priority or fair weighting queuing
DHCP, SNMP	DHCP (standard) for automatic allocation of M&C IP address. SNMP (standard) v1, v2c and v3
Web Server	Embedded web server M&C interface (standard)
IP Diagnostic Graphs	Shows Tx, Rx throughput (bps, pps); dropped, errored packet counts (standard)
IP over DVB Encapsulation Option	Supports encapsulation/ decapsulation of MPE, ULE
DVB	S2 ACM Option Dynamically varies modcod with varying link conditions, maximizing throughput at all times by converting unused link margin into additional throughput

Ethernet Traffic	
Throughput Performance	The maximum modem throughput depends on IP traffic format and the features enabled. Bridged IP/ UDP data can be processed up to the modem maximum data rate. Please seek assistance in evaluating your particular requirements.
Routing and Bridging	Bridging (standard).Static routing (standard). Dynamic routing option: RIP V1, V2; OSPF V2, V3; BGP V4
TCP Acceleration Option	Typical throughput level of 90% of link capacity. Supports 5,000 concurrent accelerated TCP connections (plus at least 35,000 unaccelerated TCP connections) up to the modem maximum data rate.

ODU facilities via IF interface	
FSK Control	Allows monitor & control of a compatible L-band BUC or IF Transceiver from the modem via the Tx IFL cable

SCPC Satellite Modem(5-155 Mbps), (70-140MHz/L), IF RMOD-SCPC-multi IF-p3

Simu-Carrier	
Simu-Carrier	Transmit and receive carriers are overlaid on top of each other in the same space segment. Echo cancellation techniques are used in the demodulator to cancel the transmit carrier and extract the wanted receive carrier signal
Simu-Carrier data rate options	256kbps, 512kbps, 1024kbps, 2.5Mbps, 5Mbps, 10Mbps, 15Mbps, 20Mbps, 25Mbps, 30Mbps, 40Mbps, 50Mbps, 60Mbps, 80Mbps, 100Mbps and 155Mbps traffic rate (30kHz to 54MHz occupied bandwidth)
Power asymmetry	-10dB to +10dB
Symbol rate asymmetry	Up to 12:1
Eb/No degradation	Typically < 0.5dB (0.7dB for 16QAM/16APSK with 10dB power asymmetry)
Mobile Operation	Uses GPS data to continually recalculate position relative to satellite, allowing uninterrupted operation in mobile environments (ships, etc.) anywhere in satellite footprint

Drop & Insert Option	
Bearer Types	T1-D4, T1-ESF, E1-G.732
Timeslot Selection	Independent selection of arbitrary timeslots for both drop and insert.
Bearer Generation	Terrestrial bearer may be looped through modem, or terminated after Drop Mux and a new bearer generated by the insert Mux
Timeslot ID	Maintains the identity of individual Drop/Insert timeslots for N=1,2,3,4,5,6,8,10,12,15,16, 20, 24 and 30. (See extended option below)

Extended Drop & Insert Option	
Multi-Destination Working	All or only a subset of the received data may be inserted into the terrestrial bearer on the receive path for multi-destinational working
Timeslot ID Maintenance	The framed service is extended to maintain the identity of individual timeslots for all values of N from 1 to 31
Signaling	CAS and RBS are fully supported

Advanced ESC		
ESC/Aux Port	Provides high-rate async ESC or Intelsat low-rate async IBS ESC	
Electrical Interface	IP, RS232, RS422 or RS485	
Async ESC	Closed Net Plus ESC	Overhead scales to any ESC baud rate from 0.5% to 70% of the main channel rate
Async ESC	IBS Option	High-rate async channel (1/32nd to 2/32nd of the IBS overhead) providing async baud rates from 0.2% to 5.1% of the terrestrial rate
Advanced Aux	Intelsat low-rate async ESC carried In bit 1 of TS32 providing a synchronous channel at 1/480th of the data rate, allowing up to one quarter of this rate for over-sampled async data	

SCPC Satellite Modem(5-155 Mbps), (70-140MHz/L), IF RMOD-SCPC-multi IF-p3

DVB-S2 Performance at PER 1e-6 Guaranteed Es/No (dB) for Normal (64k) Frames											
	Rate 1/4	Rate 1/3	Rate 2/5	Rate 1/2	Rate 3/5	Rate 2/3	Rate 3/4	Rate 4/5	Rate 5/6	Rate 8/9	Rate 9/10
QPSK	-1.6	-0.7	0.3	1.5	2.8	3.4	4.3	5.0	5.5	6.5	6.7
8PSK					6.4	7.2	8.5		9.8	11.0	11.3
16APSK						9.7	10.8	11.6	12.2	13.4	13.7

DVB-S2 Performance at PER 1e-6 Guaranteed Es/No (dB) for Short (16k) Frames											
	Rate 1/4	Rate 1/3	Rate 2/5	Rate 1/2	Rate 3/5	Rate 2/3	Rate 3/4	Rate 4/5	Rate 5/6	Rate 8/9	Rate 9/10
QPSK	-1.3	-0.4	0.5	1.9	3.0	3.5	4.4	5.2	5.6	6.7	
8PSK					6.5	7.3	8.6		9.9	11.2	11.3
16APSK						9.8	11.1	11.7	12.3	13.5	

Guaranteed Eb/No BER Performance (dB) (Typical in brackets)						
		Rate 1/2	Rate 3/4	Rate 7/8	Rate 2/3	Rate 0.93
Viterbi QPSK	1E-4	4.4 (4.4)	6.1 (5.8)	7.1 (6.8)		
	1E-8	7.2 (6.9)	8.8 (8.5)	9.5 (9.2)		
Sequential (64kbps)	1E-4	4.3 (4.0)	5.4 (5.1)	6.4 (6.1)		
	1E-8	6.4 (6.1)	7.3 (7.0)	8.6 (8.3)		
Sequential (2048kbps)	1E-4	5.6 (5.3)	6.1 (5.8)	6.9 (6.6)		
	1E-8	7.5 (7.2)	8.1 (7.8)	8.4 (8.1)		
Turbo (TPC) QPSK	1E-4	2.7 (2.4)	3.5 (3.2)	4.1 (3.8)		
	1E-6					6.3 (6.0)
Turbo (TPC) 8PSK	1E-4		5.6 (5.3)	6.8 (6.5)		
	1E-6					9.2 (8.9)
Turbo (TPC) 16QAM	1E-4		6.8 (6.3)	7.2 (6.8)		9.9 (9.6)
	1E-8					
8PSK/TCM	1E-3				6.3 (6.0)	
	1E-6				10.4 (10.1)	
	1E-4				6.1 (5.8)	
8PSK/TCM + Reed-Solomon (all rates)	1E-10				7.3 (7.0)	

SCPC Satellite Modem(5-155 Mbps), (70-140MHz/L), IF RMOD-SCPC-multi IF-p3

Mechanical Environmental	
Size	1U chassis, 410mm deep excluding front panel handles and rear panel connectors and fans
Weight	3.5kg
Power Supply	100-240VAC, +6%, -10%, 1A @100V, 0.5A @ 240V, 47-63Hz Fused IEC connector (live and neutral fused); 48V DC option
Safety Standards	EN60950-1
Emission and Immunity	EN55022 Class B (Emissions) EN55024 (Immunity)
Operating Temperature	0 to 50°C
Compliance	FCC, CE and RoHS compliant
Humidity	95% relative humidity, non-condensing
Alarm Relays	4 Independent Form C relays for unit, Tx, Rx and backward alarms

BER Testing Option	
BER Channel	Bit error rate tester operates over main traffic, ESC or Aux channels, allowing BER monitoring while on traffic. Not available in DVB-S2 mode
Test Patterns	Various test patterns compatible with common BER testers
Other test modes	Transmit CW (pure carrier) Transmit alternate 1-0 pattern Simulated satellite delay for TCP/IP packets

Built-in Spectrum Analyser showing Signal-Under-Carrier interference detection without/with interferer present

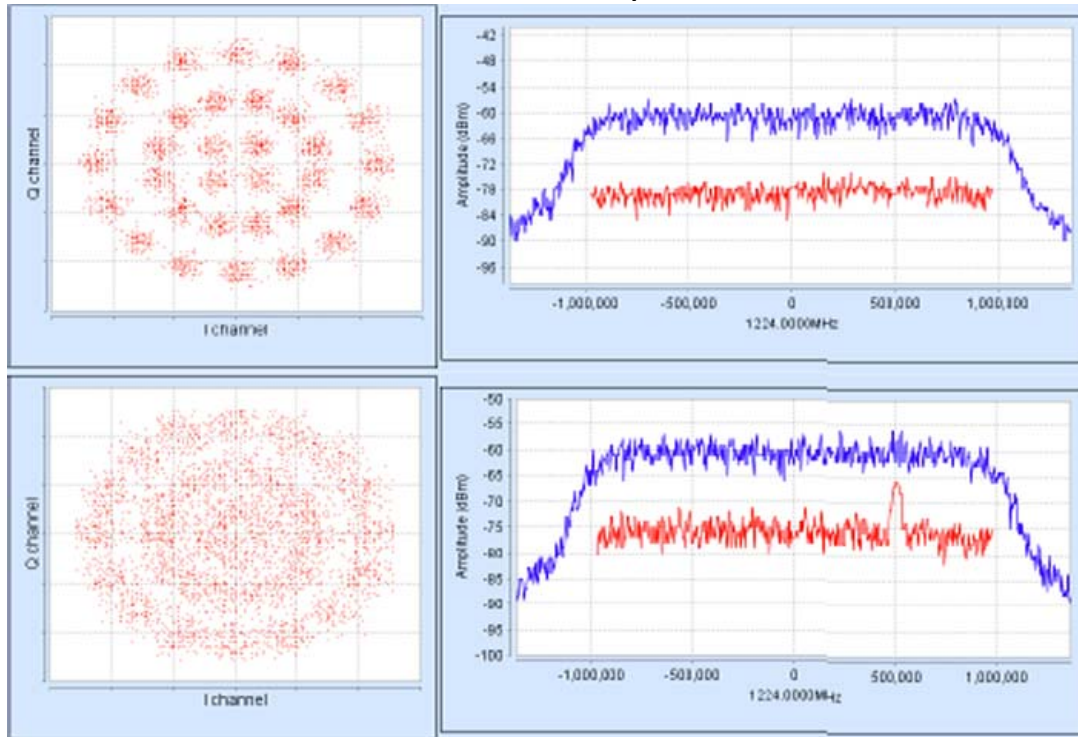



C-BAND TRANSCEIVER



70 MHz, 5 - 250 Watts



Features

- Low Phase Noise, harmonics
- 70MHz IF interface for Tx/Rx
- High frequency stability
- Excellent Gain Flatness
- Automatic shut down on failure
- Simple installation
- Trouble free maintenance
- Wide operating temperature

RADITEK's state of the art, field proven designs, up-converts from 70MHz to several C band frequency/power options. The IF interface is via a Type N(f) connector. The unit's power options include: 48V DC, 100-120V AC and 220-240V AC.

Gain adjustment and Intelligent Monitor and Control capability are accessed, via RS232/RS485. This access is via a hand held terminal, or via the IF cable (to NMS).

All units are built and tested to ISO9001, 14001, and OHSAS1801. Each unit has 3 days burn-in is and thoroughly environmentally tested.

Order Examples:

(TRANSCIVER:
C-Band Option_
(see table below)
70M (70MHz)

RTR-Ci-70M-N(f)-60W-48V-h1

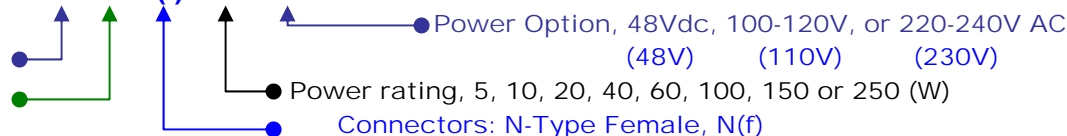

	C-Band Option	Tx Output Frequency MHz	Rx Input Frequency MHz
Cs	Standard-C	5925 ~ 6425	3700-4200
Ci	Intelesat	5850 ~ 6425	3625 - 4200
Cin	InSat	6725 ~ 7025	4500 - 4800
Cp	Palapa-C	6425 ~ 6725	3400 - 3700
Ce	Extended/ Full-C	5850 ~ 6725	3400 - 4200

Options include

- Modem Interface:
L band interface. Type N
- Input power options:
48 VDC, 100-120V, or 220-240V AC

Transmit	Technical Specification
Input Frequency	70 +/- 18MHz
Output Frequency	C Band (See Table Above)
IF Input VSWR (Interface)	1.5 : 1 (Max) (N (F))
RF output VSWR (Interface)	1.8:1 (Max) (N (F))/WG137)
Gain Adjustment	30dB @ 0.5dB step
Receive (Exclude LNA)	Technical Specification
Input Frequency	C Band (See Table Above)
Output Frequency	70 +/- 18MHz
RF Input VSWR (Interface)	1.5 : 1 (Max) (N (F))
IF output VSWR (Interface)	1.5 : 1 (Max) (N (F))
Gain	45dB max
Gain Adjustment	31dB @ 0.5dB step
Receive (LNA)	Technical Specification
Input Frequency	C Band
RF output VSWR (Interface)	1.5 : 1 (Max) (N (F))
Noise Temperature	40 K typ. at
Gain	58dB typ.
General Characteristics	Technical Specification
Temperature (operating)	-40 to 60°C
Temperature (storage)	-40 to 85°C
Humidity	0 to 100%

RTR-C-70M-N-2-250W-h1

Specifications may be subject to change

05/10/12

WORLD HQ: 1702L Meridian Ave. Suite 127, San Jose, Ca 95125, U.S.A.

Tel: (408) 266-7404

FAX: (408) 266-4483

WEB: www.raditek.com

E-mail: sales@raditek.com

C-BAND TRANSCEIVER, 70 MHz, 5 - 250 Watts L-Band, 2-80Watts

Our transceiver is enclosed in a single housing. This design facilitates quick and easy installation by direct mounting on a wide range of earth station antennas.

For requirements of 100W and above the transceiver is designed to have a low power unit with an external high power SSPA in a two housing configuration.

All can be factory configured to work in Standard-C, Extended-C, Full-C, Intelesat-C, and Insat-C band.

This is an ideal choice for any VSAT application including: wide area telephony, video conferencing and data communication systems

using SCPC/MCPC, TDMA and DAMA configuration with different modulation formats such as BPSK, QPSK and QAM.

Freq Band	Receive		Transmit				Power Supply		Mechanical		Product Highlights	
	I/P Frequency (MHz)	RF O/P : IF I/P connector	O/P Frequency (MHz)	Power @P1dB (Watt)	Power @P1dB (dBm)	Gain (dB)	IF I/p : RF O/p connector	Supply Voltage	Power Consumption	Dimension LxWxH (mm)		Wt (kg)
C Band	Intelsat (3625 ~ 4200) Palapa (3400 ~ 3700) Insat(4500 ~ 4800)	N-type (F) : N-type (F)	Intelsat (5850~6425) Palapa (6425~6725) Insat (6725 ~7025)	5	37	57	N-type (F) N-type (F)	220VAC, Option: 48VDC or 110VAC	100W	238 x 327 x126	7.7	* Single Package Transceiver + LNA, Redundancy Ready * M&C RS232 & 485, Handheld (optional) * Frequency step size of 1MHz * AC cable come with Transient protection * Guarantee performance with 16QAM Modulation * Completely independent Tx & Rx frequency Selection *2 Boxes: 1mW Driver (connect to respective SSPA via Low Loss cable) + SSPA +LNA
				10	40	60			135W	238 x 327 x 160	8	
				20	43	63			250W			
				40	46	66			360W	238 x 327 x 197	15	
				50	47	67			400W			
				60	48	67			450W			
C Band	Full C (3400 ~ 4200)	N-type (F) : N-type (F)	Full C (5850 ~ 6725)	5	37	57	N-type (F) N-type (F)	220VAC, Option: 48V or 110VAC	100W	238 x 327 x126	7.7	
				10	40	60			135W	238 x 327 x 160	8	
				20	43	63			250W			
				40	46	66			360W	238 x 327 x 197	15	
				50	47	67			370W			
				60	48	67			380W			
C Band	Full C (3400 ~ 4200)	N-type (F) : N-type (F)	Full C (5850 ~ 6725)	100	50	68	N-type (F) N-type (F)	220VAC, Option: 110VAC	900W	495 x 265 x 215	22	
				150	52	68			1100W			
				200	53	70			1500W	600 x 450 x 335	38	
				250	54	70			1700W			
				1mW +	0	35			10W	238 x 327 x 126	7	

Common	Technical Specification	
Gain flatness	±1dB (over IF band)	
	±2dB (over RF band)	
Gain stability	±2.0dB (-40 to 60°C)	
Frequency Step Size	1MHz or 5 MHz (Full C: Independent Tx & Rx adjustment and Frequency step size: 1MHz)	
Frequency Stability	+/- 0.5 ppb/day	
Inter-modulation	-27dBc @ 3dB Output Power back off	
Second Harmonic/ Spurious	55 dBc	
Phase Noise	@100Hz	-63dBc/Hz (Typ)
	@1kHz	-73dBc/Hz (Typ)
	@10kHz	-83dBc/Hz (Typ)
	@100kHz	-93dBc/Hz (Typ)
M&C	Monitor via PC (RS232/RS485)	Monitor via Handheld Terminal
	1. Channel Selection	1. Channel Selection
	2. ODU Status	2. ODU Status
	3. Gain Adjustment	3. Gain Adjustment
	4. Temperature Alarm	4. Temperature Alarm
	5. Out of Lock Alarm	5. Out of Lock Alarm

Applications

- Video Teleconferencing
- Broadcasting
- Wide area telephony
- Rural Telecommunications Expansion
 - Backhaul Trunking
 - Back Up Network
- Private Data network
- Point of Sales System
- Emergency Link Restoration

RADITEK

SATCOM C-Band Transceiver

C-Band Transceiver, Outdoor

RTR-C-5.85-6.725-Nf-WR137-48/110/220V-g11

With Optional SSPA Booster
2W, 5W, 10W, 20W
50W, 60W, 100W
125W, 150W, 200W

Also available,
250W and 400W with 1+1
Redundancy



Our C-Band One Housing Transceiver is a low cost RF ODU (Outdoor Unit) transceiver for satellite communication. It is designed for voice and data application operating in different modulation formats including BPSK, QPSK, QAM and FM.

This Transceiver is very compact and comprised of Power Supply, Upconverter, SSPA (Solid State Power Amplifier), Down -Converter and low phase noise synthesizers. It has a built-in M&C for remote and local monitoring and control. In addition, we have a wide range of add on SSPA booster options for higher power applications.

It is suitable for SCPC (Single Channel Per Carrier) or MCPC (Multi-Channel Per Carrier), DAMA (Demand Assigned Multiple Access) and TDMA (Time Division Multiple Access) applications

Features

- Available for all C-Band frequencies
- Broadband data transmission
- Low cost, compact model
- Easy installation & configuration
- Built-in monitor and control
- Higher power options available
- Built-in image rejection filter
- Very stable OCXO reference oscillator
- Output power monitoring
- Electronically tuneable synthesizer
- 1.0 MHz frequency step size
- Redundancy ready
- Surge protection
- 70 or 140 MHz IF interface

Applications

- Hub and VSAT terminals
- Video conferencing
- Broadcast
- Rural telephony
- Emergency link restoration
- Point-of-sales

Enhanced Monitoring and Control

Offers M&C via RS232/485. It features full remote M&C through Windows using PC or WinCE PDA.

These include:

- Tx/Rx level monitoring
- Temperature monitoring
- RF output ON/OFF
- Frequencies selection
- Gain control
- Automatic fault identification & alarm

Reliability

Field proven under harsh environmental conditions. It can withstand temperature ranging from -40°C to +60°C with up to 100% humidity.

Quality Assurance

72 hours burn-in at +60°C with performance being monitored.

In addition, all units undergo 100% waterproof test equivalent to IP65 to ensure operation in tropical, cold and harsh environment

C-Band Transceiver

RTR-C-5.85-6.725-Nf-WR137-48/110/120V-g11

C-Band Frequency Band (GHz)		
Frequency	Transmit	Receive
Intelsat	5.850 – 6.425	3.625 – 4.225
Gorizont	5.725 – 6.275	3.400 – 3.950
Insat	6.725 – 7.025	4.500 – 4.800
ST-1/ Palapa C	6.425 – 6.725	3.400 – 3.700
JCSAT		6.225 – 6.485

Transmit			
Power	Output @P1dB (dBm)	Min. Gain (dB)	AC power consumption (VA)
1mW	0	28	25
2W	33	58	50
5W	37	62	70
10W*	40	65	100
20W*	43	68	150
50W*	47	72	250
60W*	48	73	350
100W*	50	75	450
125W	51	76	500
150W*	51.7	77	600
200W*	53	78	800

Input Frequency	70±18 MHz (Optional 140±18 or 140 ±36 MHz)
Output Frequency	C-Band
Step Size	1.0 MHz
IF Input Power Range	-30 to -5 dBm
Gain Flatness for Full BW for 36 MHz BW	±2.0 dB ±1.0 dB
Gain Adjustment	20dB@1dB step
Gain Stability (-40 to 60°C)	1.0 dB max
Spurious (36 MHz BW)	-60 dBc
Intermodulation Product	-30 dBc max at 3dB BO
Phase Noise @ 100Hz offset	-60 dBc/Hz
@ 1kHz offset	-70 dBc/Hz
@ 10kHz offset	-80 dBc/Hz
@ 100kHz offset	-90 dBc/Hz
Input / Output VSWR	1.5 : 1 max
IF Input / RF Output Interface	50/75W N-type Female

Environmental	
Operating Temperature	-40 to 60°C
Relative Humidity	up to 100%

Notes:

- * Booster with 1mW driver
- + Check Availability

Low Noise Amplifier	
RF Input Frequency	C-Band
Noise temperature at 25°C	35K
Gain	55 dB typ.
Gain Flatness (36 MHz BW)	±0.20 dB max
Input VSWR	1.7 : 1
Output VSWR	1.5 : 1
RF Input Interface	WR229/G
RF Output Interface	50W N-type Female

Receive (exclude LNA)	
RF Input Frequency	C-Band
IF Output Frequency	70±18 MHz (Optional 140±18 or 140±36 MHz)
Step Size	1.0 MHz
Gain	45 dB min
Gain Flatness for Full BW for 36 MHz BW	±2.0 dB ±1.0 dB
Gain Stability (-40 to 60°C)	±2.0 dB
Spurious (36 MHz BW)	-60 dBc max
Intermodulation Product	-35 dBc
Phase Noise @ 100Hz offset	-60 dBc/Hz
@ 1kHz offset	-70 dBc/Hz
@ 10kHz offset	-80 dBc/Hz
@ 100kHz offset	-90 dBc/Hz
Input / Output VSWR	1.5 : 1 max
RF Input / IF Output Interface	50/75W N-type Female

Monitor And Control	
Interface	RS 232/485
Form 'C' Relay Contacts	Optional

Power Supply	
Input Voltage (Factory Preset)	220Vac, 110Vac or 48Vdc
DC Output Voltage to LNA / LNB	12Vdc at RF IN Connector

Mechanical	Weight
Size	
340L x 255W x 70H mm	(1mW, 2W, 5W SPT)
328L x 230W x 200H mm	(10W, 20W, 50W, 80W Booster)
420L x 410W x 210H mm	(100W, 125W, 150W, 200W Booster)
7.0 kg	(1mW, 2W, 5W SPT)
14 kg	(10W, 20W, 50W, 80W Booster)
23.5 kg	(100W, 125W, 150W, 200W Booster)

C-Band Transceiver

RTR-C-5.85-6.725-Nf-WR137-48/110/120V-g11

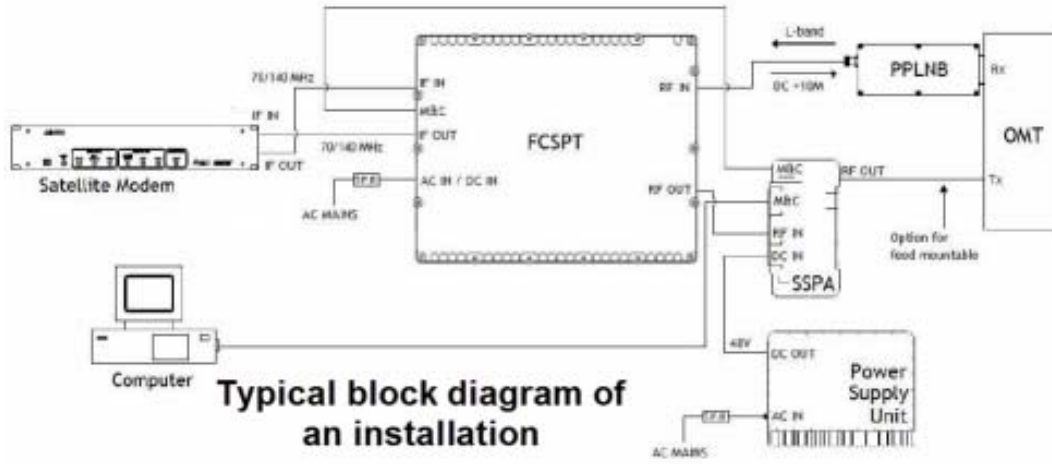



BUC, L to Ku Band,
 230VAC, Ext Reference 10M, 200W, 1+1
 RBUC-14.0-14.5(L-Ku)-230VAC-ER 10M-200W-1+1-g11

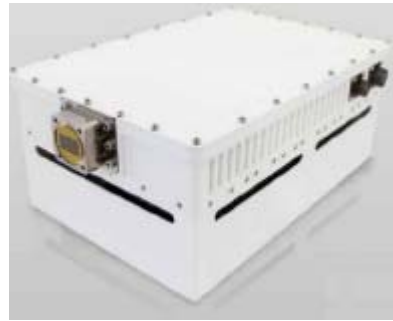

Small and lightweight our BUC is ideal for mobile and satellite uplink applications. This unit works on a wide range AC power supply of 96VAC to 264VAC. Innovative and efficient thermal design.

Make it one of the smallest, robust, reliable and Rugged enough to withstand outdoor conditions in the industry.

Built-in redundancy feature eliminates the use of an external controller for 1:1 redundancy operation.

This eliminates messy cabling at the antenna making this a very elegant solution.

Extensive M/C interface with RS232/RS485/Ethernet (SNMP & HTTP) & Bluetooth.

Features

- Compact and lightweight
- Available in standard and extended Ku-Band
- Forward & reverse power detection
- Input power detection
- Intuitive monitoring & control through RS232/RS485 & Ethernet (SNMP & HTTP) and Bluetooth
- Automatic fault identification & alarm generation
- Temperature compensation facility
- Built-in redundancy facility
- Built-in 10MHz reference with auto-detection
- Built-in receive reject filter
- Sample port for output monitoring
- Wide operating temperature range -40°C to +60°C
- RoHS Compliant
- Waterproof

RF Specifications

Transmit Frequency	14.00GHz – 14.5GHz 13.75GHz – 14.5GHz	Gain Flatness Full Band	±2dB
IF Frequency Range	950MHz – 1450MHz 950MHz – 1700MHz	Gain Slope over 40MHz	±1dB
LO Frequency	13.05GHz 12.80GHz	Gain Variation over temperature	±2dB @ from -40°C to +60°C
Output Power P_{sat} / P_{Linear}		Gain Control	20dB in steps of 0.5dB
80W	49dBm / 46dBm	O/P spurious	According to EN301428
125W	51dBm / 48dBm	Phase Noise @ Offset	
200W	53dBm / 50dBm	1KHz	-73dBc/Hz
Spectral Re growth	30dB @ P _{Linear}	10KHz	-83dBc/Hz
Third Order Intermod (two tone)	2EdBo @ two signal 2MHz apart at P _{Linear}	100KHz	-93dBc/Hz
Small Signal Gain		IP VSWR	1.3:1
80W	70dB Min	O/P VSWR	1.25:1
125W	75dB Min	Noise Power Density Tx BD	70dBW/4KHz
200W	75dB Min	Rx RD	142dBW/4KHz

BUC, L to Ku Band 230VAC, Ext Reference 10M, 200W, 1+1

DC Power

Prime Power	230VAC (range 98V to 264VAC)
Power Consumption	
80W	500W max (500W @ P _{linear})
125W	1200W max (800W @ P _{linear})
200W	1900W max (1700W @ P _{linear})

Interfaces

IF Input Interface	50Ohms N-type Female
Output Interface	WR 75G

External Reference

Frequency	10MHz
Power	-5dBm to +5dBm
Internal reference	Built-in (Auto detection)
External reference phase noise Requirement @ frequency offset	
1KHz	-150dBc/Hz
10KHz	-155dBc/Hz
100KHz	-160dBc/Hz

Monitor and Control

Monitor	BUC temperature Status alarm Output power Reverse power Input power LED status indication
Control	Attenuation RF output mute
Interface	RS232/RS485 & Ethernet (SNMP & HTTP) Bluetooth (optional)
Tx Redundancy	Built-in

Environmental

Operating Temperature	-40°C to +60°C
Humidity	Up to 100% Weather protection sealed to IP65

Compliance Standards

IEC 609501-2nd Edition	International Safety Standard for Information Technology Equipment
ETSI EN 301 489-12	Electromagnetic Compatibility and Radio Spectrum Matters (ERM); ElectroMagnetic Compatibility (EMC) Standard for radio equipment and services; Part 12: Specific conditions for Very Small Aperture Terminal, Satellite Interactive Earth Stations operated in the frequency ranges between 4GHz and 30GHz in the Fixed Satellite Service (FSS)
ETSI EN 301 489-1	Electromagnetic Compatibility and Radio Spectrum Matters (ERM); ElectroMagnetic Compatibility Standard for Radio Equipment and Services
FCC Class A	Two levels of radiation and conducted emissions Limits for unintentional radiators (FCC Mark)

Mechanical

Size	
80W	330L x 200W x 130H mm
125W	400L x 260W x 200H mm
200W	550L x 350W x 260H mm
Weight	
80W	8.0kg
125W	17.0kg
200W	30.0kg
Color	White Powder Coat



Up Converter, (70M/ L Band) to C (5.85-6.75GHz), Indoor Unit

RUC-(70M/L) to C(5.85-6.75)-IDU-g11



Reliability

Field proven with system deployed world-wide. Raditek Up-Converters can withstand temperature from -10°C to +50°C up to 95% non-condensing humidity.

Quality Assurance

All Raditek Up-Converters are designed and manufactured according to ISO 9001 standard

Features

- Compact unit, single 1 RU package
- User selectable spectrum inversion
- Redundant Ready
- Available for wide satellite bands
- RS232, RS485 and SNMP interface for remote Monitor and Control (M&C)
- Full M&C through LCD & Keypad or serial remote

Output Parameters

Output Frequency	5.85 to 6.750GHz
Impedance	50 Ω
VSWR	1.6:1
Output Power @P1dB	+0 dBm min

Input Parameters

Input Frequency	950-1825MHz (for L to C)
	70 ± 18MHz
Impedance	50 Ω
VSWR	1.44:1
Input Power	-5 to -25dBm

Transfer Parameters

Frequency spectrum	User selectable
Conversion Gain	28 dB min
Gain Adjustment	25 dB
Gain Flatness	±0.75 dB over 36 MHz Bandwidth ±2 dB over Full Bandwidth
Gain Stability	±0.25 dB over 24 hours at constant temperature
In Band Spurious	
Carrier dependent	-55 dBc at max gain
Carrier Independent	-65 dBm max
Out Band Spurious exclude LO	-60 dBm max
Third order intermodulation products	40dBc @w/o carrier 2MHz apart. 8dB back off from Parated for each carrier
Phase Noise	
@1KHz	-73cBc/Hz
@10KHz	-83cBc/Hz
@100KHz	-93cBc/Hz

Rear Panel Connections

IF/L Input	BNC Female (for IF to C) N-Type Female (for L to C)
RF Band Output	SMA Female
10MHz Ext REF Connector (Optional)	BNC Female
Remote Connector	DB 9 Female
Power IN	AC/DC

Monitor and Control

Interface	RS232/ RS485/ SNMP
Monitoring parameters	LO & Temperature Alarms
Control Parameters	Gain Adjustment @ 0.5 dB Step

Power Supply (Optional)

AC Input Voltage	100 to 240Vac 50/60 Hz
Power Consumption	35W

Environmental

Operating temperature	-10°C to 50°C
Humidity	up to 95% (Non-condensing)

Mechanical

Dimension	480L x 330W x 44H mm
Weight	3.5kg (for L to C) 4kg (for IF to C)

Up Converter, (70 L Band) to C Band (5.85-6.75GHz), Indoor Unit

ADDITIONAL SPECS for C Band Up Converter	
Type	<ul style="list-style-type: none"> · Synthesized up conversion. · Dual conversion · No inversion · Image rejection -80 dBc in band
Step size	125 KHz
Stability (time)	$\pm 1 \times 10^{-9}$ /day
Stability (temp)	$\pm 1 \times 10^{-8}$ /day
Preset channels	32 frequencies
IF INPUT CHARACTERISTICS	
Return loss	23 dB minimum
RF OUTPUT CHARACTERISTICS	
Output level	+5 dBm @1 dB comp
Carrier mute	-70 dBc
Spurious	Carrier: -60 dBc at 0 dBm output
Inter mod	-40 dBc (2 carriers) @ 0 dBm output
Return loss	20 dB minimum
Connector (IF)	N-TYPE Female
TRANSFER CHARACTERISTICS	
Gain (minimum)	28 dB
Gain adjust (minimum)	25 dB min in 0.5 dB steps or less
Ripple	± 0.25 dB over 36 MHz Span
Gain slope	0.05 dB/MHz
IF band width	36 MHz
AM to PM conversion	0.1 deg/ dB @ -5 dBm output
GROUP DELAY	
Linear	0.03ns / MHz
Parabolic	0.01ns / MHz ²
Ripple	1.0ns peak - to - peak
POWER SUPPLY	
Voltage	200 to 240 VAC, 50 \pm 10% Hz Single Phase

FRONT PANEL	
Display (LCD)	Indication & control of Frequency, input attenuator, status, channel, Gain etc
Test points	RF port, IF port
LED Indicators	Power, External Ref, Remote, RF ON, LO fault, Signal Fault
REAR PANEL	
RF out / IF	in N/ BNC
Ref out / in	5/10 MHz, BNC female
M&C interface	Ethernet LAN (SNMP with Web enable), RS 485/ RS232

OTHERS	
Size of single converter	19" rack mountable, standard 1U height
MTBF	55,000 Hrs (Typical)
Warranty	2 Years



BUC, C-Band, 10M External Reference, 2W RBUC-C-10M ER-2W-w13

Special Features

- 33dBm output power
- RoHS Compliance
- Small Size & Mass
- Low DC Power Consumption (25W Max.)
- Two years Warranty

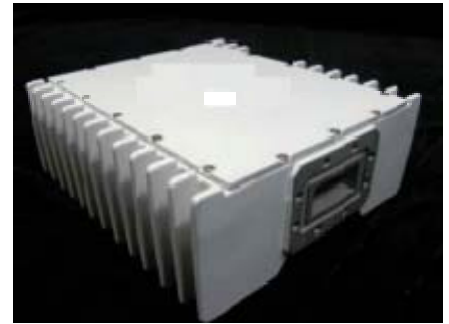

Description	RF Band (GHz)	IF Band (MHz)	Output Power (dBm)
Standard	5.85– 6.425	950 -1525	+33
Palapa	6.425-6.725	1150-1450	+33
Insat	6.725-7.025	975-1275	+33

Order Examples: RBUC-5.85-6.425G, 10M ER -2W-w13

Description: (BUC-5.85-6.425GHz, 10MHz External Reference, 2 Watts)

Specifications		Units
Input Characteristics		
Frequency Range	950 -1525 1150 - 1450 975 - 1275	MHz
Impedence	75 , 50	Ohm
VSWR	2:1	
Interface	N-Type (std.) or F-Type (via adapter)	
Output Characteristics		
Frequency Range	5.85 ~ 6.425 (LO-4.9 GHz) 6.425 ~ 6.725 (LO-5.275 GHz) 6.725 ~ 7.025 (LO-5.75 GHz)	GHz
1dBCompressionPoint. Min	33	dBm
VSWR	2:1	
Interface	CPR137G	
Transfer Characteristics		
Frequency Sense	Non-inverted	
Linear Gain (Typical)	55	dB
Gain Variation Over 54MHz	1.5	dB
Over the whole Bandwidth	4	
Over Operation Temperature	4	
Spurious In band	-60	dBc
Out of band	-50	

BUC, C-Band, 10M External Reference, 2W RBUC-C-10M ER-2W-w13

Specifications			Units
Phase Noise	100Hz	-60	dBc/Hz
	1KHz	-70	
	10KHz	-80	
	100KHz	-90	
<i>External Reference</i>			
Input Frequency		10	MHz
Input Power @Input Port		-5 to +5	dbm
Phase Noise	@ 100Hz offset	-125	dBc/Hz
	@ 1kHz offset	-135	dBc/Hz
	@ 10kHz offset	-140	dBc/Hz
Operating Voltage DC		15 ~ 24	VDC
Power Consumption (Max.)		25	W
Operating Temperature		-40 ~ +55	°C
Humidity		Up to 100	%
Internal Function		Lock Detector shuts off Tx in case of LO unlocked	
Dimensions		176.1 X 161.5 X 65 / (6.9 x 6.4 x 2.6)	mm/ (in.)
Weight		1.8 / (4)	Kg/ (lb)

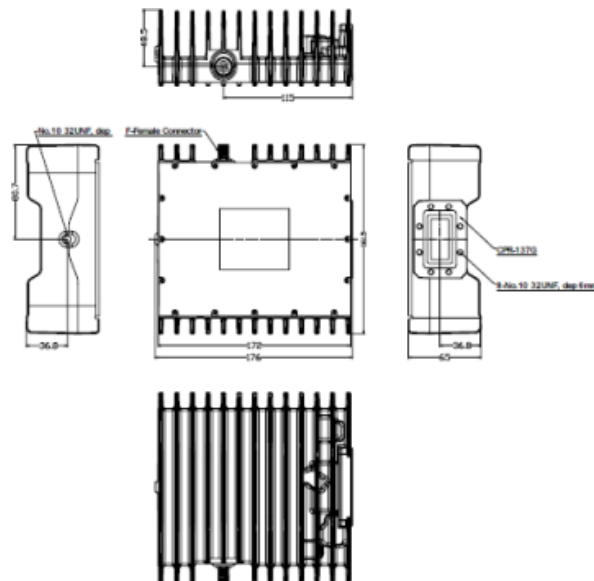

Mechanical Drawing



C BAND BUC (Block Up Converter)



L Band, 2-250Watts

(Low/Medium/High Power), 15- 220 V



Low Power

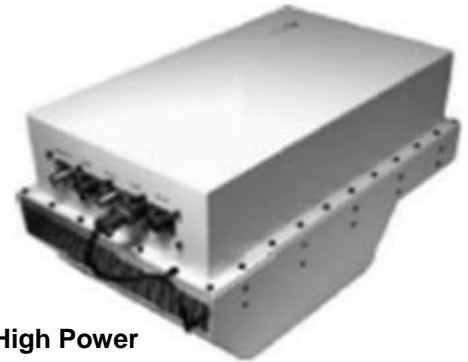

High Power



Medium Power

Product Highlights:

- Adjustable gain via Dip Switch
- Low Cost, Low Power, Light Weight
- Light and mounts directly to antenna
- Single Package
- Gain adjustment@0.5dB step sizes
- Redundancy ready
- Handheld Optional
- M&C RS232 & 485
- FSK optional for 5W to 60W
- AC Cable c/w Transient protection

RADITEK's state of the art, field proven design, up converts from L Band to several C band frequency options*

- The IF port interfaces via Type "N" female connectors.
- The unit runs off: 48Vdc, 100-120Vac, and 220-240Vac.
- Gain adjustment and intelligent Monitor and control is accessed, via RS232/RS485, via a hand held terminal, or via the IF cable (to NMS).
- All units are built and tested to ISO9001, 14001, and OHSAS1801.
- Each unit has 3 days burn-in is and thoroughly tested.

Features:

- L band IF
- Low Phase Noise, harmonics and Spurious
- Automatic shut down alarm

Applications:

- Private Data Network
- Telephony backhaul for remote access
- Video Teleconferencing
- SCPC, TFMA, etc.

Options include:

- Bands: Standard-C, Intelesat, InSat, Palapa-C, Full-C
- Modem Interface: L
- L band interface. Type N(f)
- Output power options (Watts):
2, 5, 10, 20, 60 100, 150, 200, 250
- Input power options:
48Vdc, 100-120V, or 220-240V AC

See also RADITEK, LNBs and leading IP based Modems, Transceivers with 70 MHz interface, etc

Order Examples:

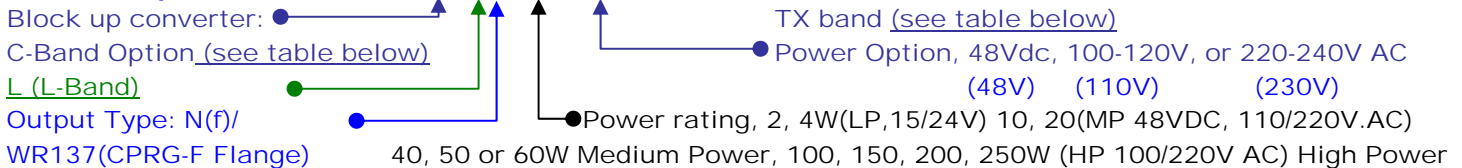

RBUC-C-L-N-2-250W-15-220V- Generic-h1

Specifications may be subject to change

02/18/11

WORLD HQ: 1702L Meridian Ave. Suite 127, San Jose, Ca 95125, U.S.A.

Tel: (408) 266-7404

FAX: (408) 266-4483

WEB: www.raditek.com

E-mail: sales@raditek.com

C BAND BUC (Block Up Converter), L Band 2-250Watts (Low/Medium/High Power), 15- 220 V

Electrical Specifications		
Input Frequency	L Band – See Table	
Output Frequency	C-Band – See Table	
RF Input VSWR (Interface)	1.5:1	
Gain Flatness	±0.75 dB (over IF band, 40 MHz)	
	±1.5 dB (over RF band)	
Gain Stability	±1.5dB (-40 to 55°C)	
Frequency Stability	±0.5 ppb/day	
Inter-modulation	-27 dBc max@3dB Output power back off	
Second harmonic/Spurious	-55dBc	
Phase Noise	@ 100Hz	-63dBc/Hz
	@1kHz	-73dBc/Hz
	@10kHz	-68dBc/Hz
	@100kHz	-93dBc/Hz
Internal Reference Option (Extd. Std)	Frequency Reference	10MHz @ -5 ~+ 5dBm
	Frequency Mode	External (Internal Option)
	Frequency Stability	Same as External Reference
General Characteristics		
Environmental	Temperature (operating)	-40 to 60
	Temperature (storage)	-40 to +85
	Humidity	0 to 100%
Monitor & Control function	Monitor BUC thru PC Terminal (RS232/RS485)	Monitor BUC thru PC Terminal IFL via Modem with FSK Option
Monitor	Lock/Unlock	Lock/ Unlock status
	Temperature Reading	Temperature Reading
	RF output power reading	RF output power reading
		Reading from Modem L Band frequency
Control	SSPA On/Off	SSPA On/off
	Gain adjustment	
Input Connector L Band	N(f)	
Size		
Dimensions mm / weight	Low Power 2 - 5 W	250x150x60mm/ 2.5 kg
	Medium Power 5 - 20W	238x327x160mm / 5 kg
	Medium Power 40 - 60 W	239x327x197mm / 15 kg
	High Power 100-150 W	495x265x215mm / 22 kg
	High Power 200-250 W	600x450x335mm/ 38 kg

C BAND BUC (Block Up Converter), L Band 2-250Watts (Low/Medium/High Power), 15- 220 V

AC Power

The "Low & Medium Power Series" BUC can be configured to power by the AC supply of 220-240 or 100-120AC via a separate AC connector.

The AC cable comes with the Transient protection capability which protects the BUCs unit directly from high voltage/current transient. They are designed with intelligent M&C capability.

Monitoring & Control

Setup and monitoring & control can be done remotely via RS232/RS485.

The set up of the BUC can also be done with our convenient handheld terminal through RS232 connection.

We also offer an option feature of FSK for the user to monitor and control the units at the Satellite Modem via IFL cable.

IFL Cable

The IFL cable transports the L Band Signal, 10MHz External reference, and FSK signal (optional), M&C signal (optional) as well DC Power (24V). All these signals are multiplexed from the Modem to the BUC via the IFL cable.

C-Band Option	Satellite	L -Band MHz	TX-RF Output MHz	LO Freq MHz
Cs	Standard-C	950 -1450	5925 ~ 6425	7375
Ci	Intelesat	950-1525	5850 ~ 6425	7375
Cp	Palapa-C	950-1250	6425 ~ 6725	7675
Cin	InSat	965-1265	6725 ~ 7025	5760
Ce	Extended-C	950-1625	5850 ~ 6725	7675

Power @ P1dB (Watt)	Power @ P1dB (Watt)	Gain dB	Power Voltage VDC	Power Consumption Watt	C Band TX RF Output Connector
2	33	70	15/	35	N(f) or WR137 CPRG-F Flange
5	37	70	24V	40	
5	37.0	67	110/ 220V AC 48V DC	100	N(f)
10	40.0	70		125	
20	43.0	73		200	
40	46.0	76	110/ 220V AC	350	
50	47.0	77		400	
60	47.8	78		450	
100	50.0	68	110/ 220 VAC	900	WR137 CPRG-F Flange
150	51.8	68		1100	
200	53.0	70		1500	
250	54.0	70		1700	



BUC, Ku-Band,
10MHz External Reference, 8W
RBUC-Ku-10M ER-Nf-8W-w13



Special Features-

- 39dBm output power
- 18~60VDC
- Optional MS Connector
- Low DC Power Consumption
(75W Max.)
- Two years Warranty



RF Band (GHz)	IF Band (MHz)	Output Power (dBm)
14.00 - 14.50	950 -1450	+39
13.75 - 14.25	950 -1450	+39
13.75 - 14.50	950 -1700	+39

Order Examples: RBUC-14.0-14.5G-10M ER-Nf-8W-w13

Description: (BUC-14.0-14.5GHz-10MHz External Reference, N female Connectors, 8 Watts)

Specifications		Units
Input Characteristics		
Frequency Range	950-1450 950-1450 950-1700	MHz
Impedence	75 , 50	Ohm
VSWR	2:1	
Interface	N-Type (std.) or F-Type (via adapter)	
Output Characteristics		
Frequency Range	14.00 ~ 14.50 (LO Freq - 13.05) 13.75 ~ 14.25 (LO Freq = 12.80) 13.75 ~ 14.50 (LO Freq = 12.80)	GHz
1dBCompressionPoint. Min	39	dBm
VSWR	2:1	
Interface	WR75G	
Transfer Characteristics		
Frequency Sense	Non-inverted	
Linear Gain Typical	65	dB
Gain Variation Over 54MHz	1.5	
Over the whole Bandwidth	4	dB
Over Operation Temperature	4	
Spurious In band	-60	dBc
Out of band	-50	

BUC, Ku-Band, 10MHz External Reference, 8Watts RBUC-Ku-10M ER-8W-w13

Specifications Specification			Units
Phase Noise	100Hz	-60	dBc/Hz
	1KHz	-70	
	10KHz	-80	
	100KHz	-90	
Miscellaneous			
<i>External Reference</i>			
Input Frequency	10		MHz
Input Power @Input Port	-5 to +5		dBm
Phase Noise	-125		dBc/Hz @ 100Hz offset
	-135		dBc/Hz @ 1kHz offset
	-140		dBc/Hz @ 10kHz offset
Operating Voltage DC	18 ~ 60 (Opt. MS Connector)		VDC
DC Power Consumption (Max.)	76		WDC
Operating Temperature	-40 to +55		°C
Humidity	Up to 100		%
Internal Function	Lock Detector shuts off Tx in case of LO unlocked		
Dimensions / Weight	175.4 X 169 X 101 / (6.9x6.7x4)		mm/ (in)
Weight	2.7/(1.22)		Kg/ (lb)

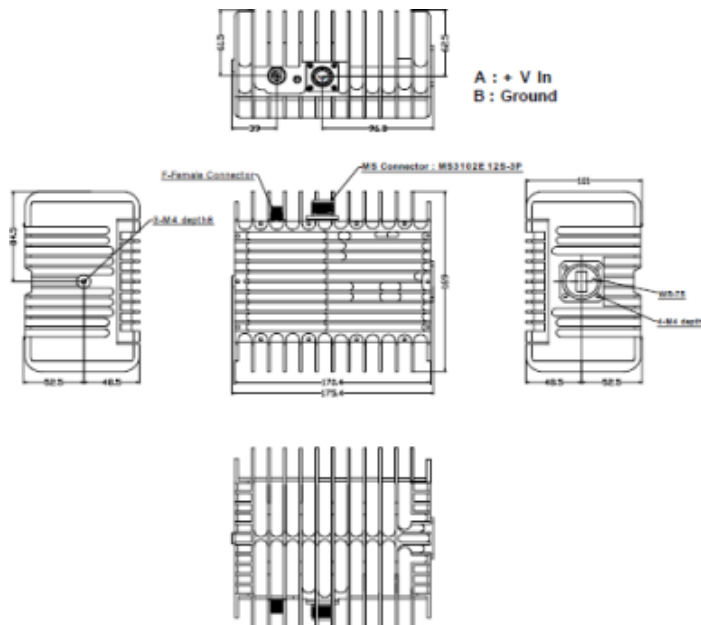

Mechanical Drawing

RADITEK

SATCOM

L-C Band BUC - ODU

Block Up Converter-L to C Band

Nf/WR137 -Ext Ref, Outdoor Unit

RBUC-L to C(f1-f2)-Nf/WR137-XW-ER-ODU-g11

(Frequency & Power table on pg 2)

Applications Designed for:

- SCPC (Single Channel per Carrier)
- MCPC (Multi-Channel per Carrier)
- DAMA (Demand Assigned Multiple Access)
- Or TDMA (Time Division multiple Access)



Order Examples: RBUC-L-C(5.850-6.725)-Nf / WR137-5W-ER-ODU-g11

Description: (BUC, L to C-Band(5.850-6.725GHz), Nf/ WR137, 5Watts, External Reference (ER), Outdoor Unit)

Features

- Available for all C-Band frequencies
- L-Band Interface
- Low cost, compact
- Direct antenna mount
- Easy installation
- Temperature compensation
- High power options
- Redundancy option
- RS 232/485, FSK & SNMP M&C option
- Excellent phase noise characteristics
- Low spurious
- Low power consumption
- Wide input D.C. voltage range

Reliability

Field proven under harsh environment conditions. ODU's can withstand temperature ranging from -40°C to +60°C with up to 100% humidity.

Monitoring and Control (Optional)

- SSPA On/Off control
- Automatic level control with level stability accuracy better than ± 0.5 dB
- Adjustable gain
- Temperature sensor reading
- LO unlocked alarm
- Input Power Detection
- Output Power Detection
- SNMP
- FSK

Quality Assurance

All ODU's go through intensive active electrical stress screening with performance being monitored during screening. In addition, all outdoor units undergo 100% waterproof test equivalent to IP65 to ensure normal operation during tropical, cold and harsh environment.

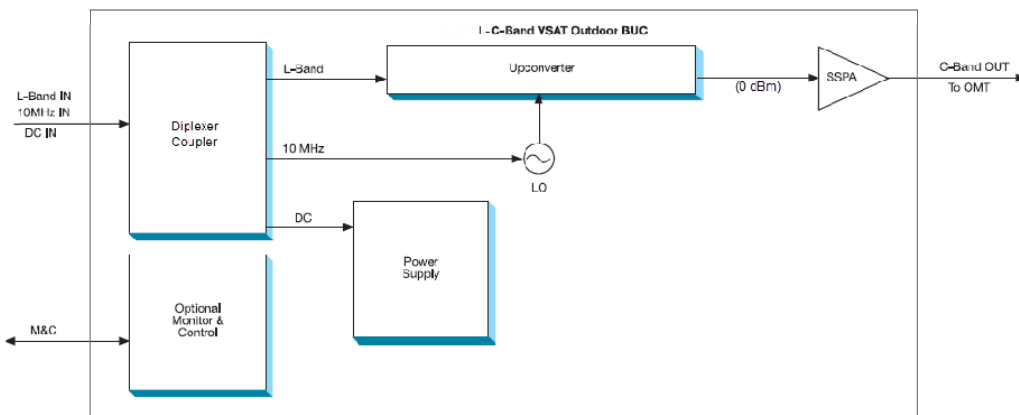

BUC-L to C Band - Nf/WR137 -External Reference, Outdoor Unit RBUC-L to C-Nf/WR137-XW-ER-ODU-g11

Frequency Range (MHz)			
	Input	Output	LOW LO
Intelsat	950 to 1525	5850 to 6425	4900
Insat	1100 to 1400	6725 to 7025	5625
Measat 3	950 to 1750	5925 to 6725	4975
ST-1/Palapa-C	1150 to 1450	6425 to 6725	5275
Full C	950 to 1825	5850 to 6725	4900

Mechanical	
Dimensions	187L x 131W x 56H mm (1mW,2W) 248L x 145W x 56H mm (5W) 248L x 145W x 94H mm (10W) 210L x 150W x 90H mm (20W, 25W) 235L x 175W x 90H mm (40W, 50W) 430L x 278W x 260H mm (60W) 525L x 285W x 275H mm (80W to 150W) 610L x 328W x 251H mm (200W) 474L x 464W x 416H mm (250W to 500W)
Weight	1.8 kg (1mW to 2W) 2.8 kg (5W) 3.0 kg (10W) 3.0 kg (20W) 3.9 kg (40W to 50W) 16.0 kg (60W) 23.5 kg (80W to 150W) 55 kg (250W to 500W)
Color	White powder coat

Power Supply	
Operating Voltage	+18Vdc to +36Vdc (1mW to 2W) +18Vdc to +60Vdc (5W to 10W)
AC Input Voltage for Booster	220Vac or 110Vac (Factory preset)
DC Input Voltage for BUC 20W Above	+48 Vdc (Optional)
Monitor And Control (optional)	
Interface	RS 232/485, FSK & SNMP
SSPA Output Power Detect	Yes
SSPA On/Off Control	Yes

Environmental	
Operating Temperature	-40°C to + 60°C
Relative Humidity	up to 100% Weather Protection sealed to IP65
External Reference	
Frequency	10 MHz
Phase Noise	External Reference Dependent
Power	-5 to +5 dBm @ 50I

Trasmit			
Power	Output P1dB (dBm) min	Gain (dB)	Power Consumption (Typ)
1mW	0	26 – 34	4.5W
2W	33	55 – 63	24W
5W	37	56 – 64	38W
10W	40	63 – 71	77W
20W	43	66 – 74	120W
25W	44	66 – 74	150W
40W	46	69 – 77	200W
50W	47	69 – 78	230W
60W*	47.8	76 – 80	350VA
80W*	49	78 – 82	500VA
100W**	50	79 – 83	700VA
150W**	52	81 – 85	1000VA
200W**	53	82 – 86	1200VA
250W**	54	83 – 87	1600VA
300W**	54.8	83 – 87	1800KVA
400W**	56	83 – 87	2000KVA
500W**	57	83 – 87	2400KVA

Input Power @P1dB Output	-25 dBm (Typ)
Gain Flatness over Full Bandwidth	4 dB max
Gain stability Over Temp	4 dB max
Spurious @ P1dB Output	-55 dBc max
Phase Noise @ 100Hz offset @ 1kHz offset @ 10kHz offset @ 100kHz offset	-63 dBc/Hz -73 dBc/Hz -83 dBc/Hz -93 dBc/Hz
Intermodulation Product	
(with 2 carriers, 1MHz apart, at 6dB back off from Output @P1dB)	-27 dBc max (below 100W) -25 dBc max (100W & above)
Frequency Inversion	Non inverting
Input VSWR	2:0:1 typ
Input Interface	50I N-Type Female / F- Type
Output Interface	Female (Optional) 50I N-Type Female (1mW) WR137G (2W to 500W)

BUC-L to C Band -
Nf/WR137 -External Reference, Outdoor Unit
RBUC-L to C-Nf/WR137-XW-ER-ODU-g11

Compliance Standard	
IEC 60950	International Safety Standard for Information Technology Equipment
ETSI EN 301 489-1	Electromagnetic Compatibility and Radio Spectrum Matters (ERM); ElectroMagnetic Compatibility (EMC) Standard for Very Small Aperture Terminal (VSAT)
ETSI EN 301 489-1	Electromagnetic Compatibility and Radio Spectrum Matters (ERM); ElectroMagnetic Compatibility Standard for Radio Equipment and Services
FCC Part 15 Class B	Two levels of radiation and conducted emissions Limits for unintentional radiators (FCC Mark) Environmental Testing Standard
IEC 60068 MIL-STD-810F	Environmental Testing Standard Environmental Engineering Considerations and Laboratory Tests

BUC + TWTA, (C, X or Ku-Band), 750W, Outdoor Unit, with optional Redundancy



Features

- L-band input
- Rugged 55lb. antenna mount package
- Extended frequency band available
- RS-232/422/485 M & C Interface
- 1:1, 1:2,1:Redundancy



Order Examples: RBUC+TWTA-13.75-14.5-750W-ODU-n6
Description: (BUC + TWTA, 13.75-14.5GHz, 750W, Outdoor Unit)

Our 750W BUC+TWTA is a series of compact self contained antenna mountable power amplifiers with a built-in Block Up Converter designed for low cost installation and long life.

Our design eliminates the need for an amplifier shelter as well as a long waveguide run between the amplifier and the antenna feed horn.

For example, an antenna mount 750 Watt Ku-Band amplifier with its shorter waveguide run will often deliver EIRP comparable to a 650 Watt rack mount HPA.

RF filters, cooling, and monitoring & control systems are all self contained within the HPA. These features provide high reliability, low maintenance costs, and low replacement costs.

This TWTA uses high efficiency dual-stage collector Traveling Wave Tubes (TWT).

Some benefits of this type of TWT are: reduced prime power consumption, lower internal operating temperatures, and reliability enhancement. These benefits are obtained for both the linear and saturated modes of operation.

The unit incorporates power factor correction circuitry, which minimizes line current distortion and reduces the required Volt-Amps. The combination of power factor correction and high efficiency TWTs reduces input Volt-Amps by 45% when compared to equivalent amplifiers. A high frequency resonant conversion power supply is used that accepts a wide range of prime power (180 to 260 VAC). The automatic features of the power supply include quick recovery from prime power outages and multiple helix arc fault resets (three fault cycles). A complete serial M&C system is built into the unit.

This TWTA may be configured for single thread, redundant, phase-combined, to linearized operation.

A remote external controller is available to operate the HPA from a user selected locations.

Mounting brackets can be supplied to mount the HPA to most popular antennas.

Parameters	C-Band	X-Band	Ku-Band
Frequency Range (extended frequency coverage available)			
Output	5.850 to 6.425 GHz	7.9 to 8.4 GHz	13.75 to 14.5 GHz
Input	950 to 1525 MHz	950 to 1450 MHz	950 to 1700 MHz
LO Frequency	4900 MHz	6950 MHz	12800 MHz
Input Level, w/o damage (maximum)	10 dBm		
Reference Signal Frequency	external 10 MHz		
10 MHz Power Level	2 dBm ± 5 dB		
Reference Input impedance	50Ω		

BUC + TWTA, (C, X or Ku-Band), 750W, Outdoor Unit, with optional Redundancy

Parameters		C-Band	X-Band	Ku-Band
<i>Output Power</i>				
Traveling Wave Tube		750 Watts		
Rated Power @ Amplifier Flange (minimum)		650 Watts		
<i>Gain</i>				
Large Signal (minimum)		67 dB		
Small Signal (minimum)		72 dB		
Attenuator Range (continuous)		25 dB		
<i>Maximum SSG Variation Over</i>				
Any Narrow Band		1.0 dB per 40 MHz	1.0 dB per 80 MHz	1.0 dB per 80 MHz
Full Band		± 2 dB		
Slope (maximum)		± 0.04 dB/MHz		
Stability, 24 hr. (maximum)		± 0.25 dB		
Stability, Temperature (maximum)		± 1.0 dB over temperature range at any frequency		
Intermodulation (maximum) with two equal carriers		-18 dBc @ 4 dB total output power back off from rated power		
Harmonic Output (maximum)		-60 dBc		
AM/PM Conversion (maximum)		2.5 deg/dB at 6 dB below rated power		
<i>Noise Power (maximum)</i>				
Transmit Band		-70 dBW/4 kHz		
Receive Band		-150 dBW/4 kHz 3.7 to 4.2 GHz	-150 dBW/4 kHz 10.95 to 12.75 GHz	-150 dBW/4 kHz 10.95 to 12.75 GHz
<i>Group Delay (maximum)</i>	Bandwidth	Any 40 MHz	Any 80 MHz	Any 80 MHz
	Linear	0.01 nS/MHz		
	Parabolic	0.005 nS/MHz ²		
	Ripple	0.5 nS/Pk-Pk		
Residual AM Noise (maximum)		-60 dBc > 100 kHz from carrier AC fundamental -50 dBc Sum of all spurs -47 dBc		
Phase Noise (maximum)		Per IESS phase noise profile; AC fundamental -50 dBc; Sum of all spurs -47 dBc		
VSWR	Input (maximum)	1.8:1		
	Output (maximum)	1.3:1		

Environment		Prime Power
Non Operating Temperature Range	-50 to +70°C	180 to 260 VAC
Operating Temperature Range	-40 to +50 °C (2 °C/1000 Feet Derating)	47 to 63 Hz, Single Phase
Humidity	Up to 100% Condensing	2450 VA (maximum)
Altitude	10,000 Feet MSL (maximum)	0.95 Minimum Prime Power Factor
Shock and Vibration	Normal Transportation	
Cooling	Forced Air	

BUC + TWTA, (C, X or Ku-Band), 750W, Outdoor Unit, with optional Redundancy

Type	Function	
Local Control	Prime Power On/Off Power Supply On/Off	Local/Remote HV On/Off
Local Status	Tri-Color LED:	
	Fault: Red	Standby: Continuous Amber
	HV On: Green	FTD: Flashing Amber
Remote Control	HV ON/OFF	Constant Power
	Min/Max Power Alarm/Fault	RF Inhibit (HV off)
	RF Attenuation (w/preamp)	Fault Reset
	Heater Standby On/Off	Units (Watts, dBm, dBW)
Remote Status	Power Out	Reflected Power
	Helix Current	Helix Voltage
	Heater/ Beam Hours	Filament Time Delay
	Attenuator Setting	HV ON
	TWT Temperature	Fault Identification
Form C Dry Contact Closure	Summary Fault	
RF Monitor Port	-43 dB Coupling Value (approximate)	

Options

Remote External Controller

- 1:1, 1:2, 1:N Redundancy
- Integrated Linearizer
- Input Diplexer (combining IF & 10 MHz reference)
- Reverse RF Inhibit
- Extended frequency coverage

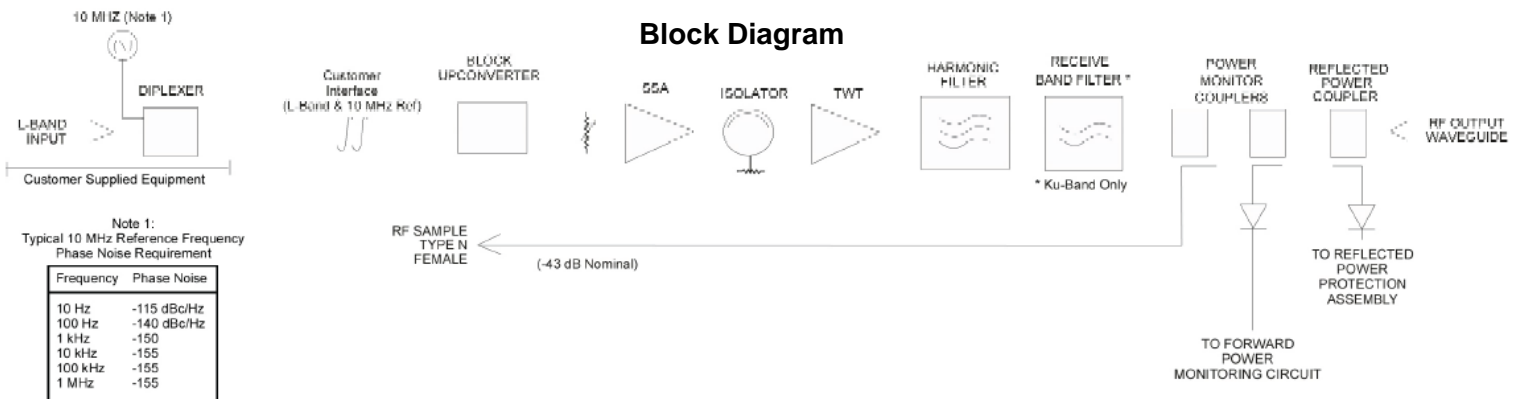

BUC + TWTA, (C, X or Ku-Band), 750W, Outdoor Unit, with optional Redundancy

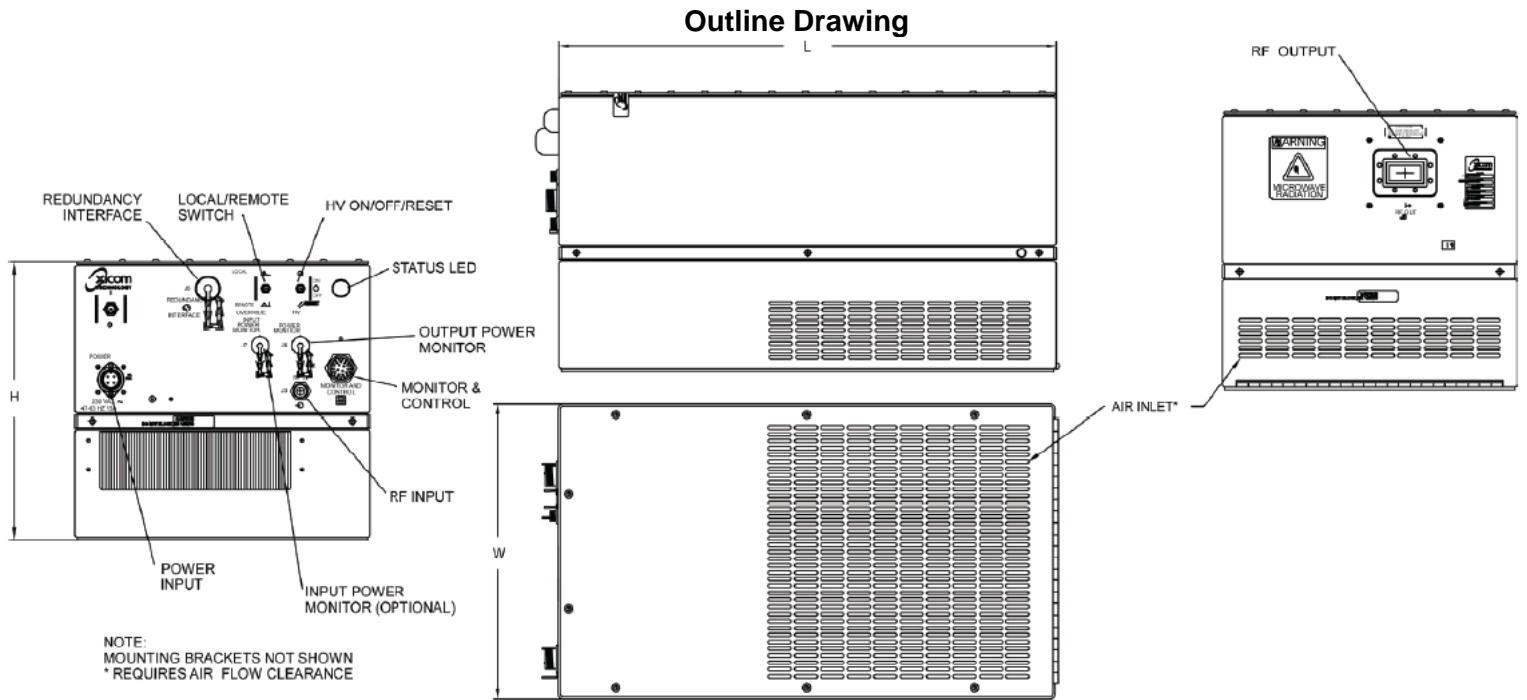

DIMENSIONS		
	INCHES	CENTIMETERS
L	21.50	54.61
H	12.13	30.81
W	12.75	32.39

Nominal Weight = 75 lbs (34.02 kg)

RF OUTPUT	
FREQUENCY BAND	WAVEGUIDE FLANGE
KU	WR-75
C	CPR-137

BUC + TWTA, (C, X or Ku-Band), 750W, Outdoor Unit, with optional Redundancy

Redundancy
1+1 Option

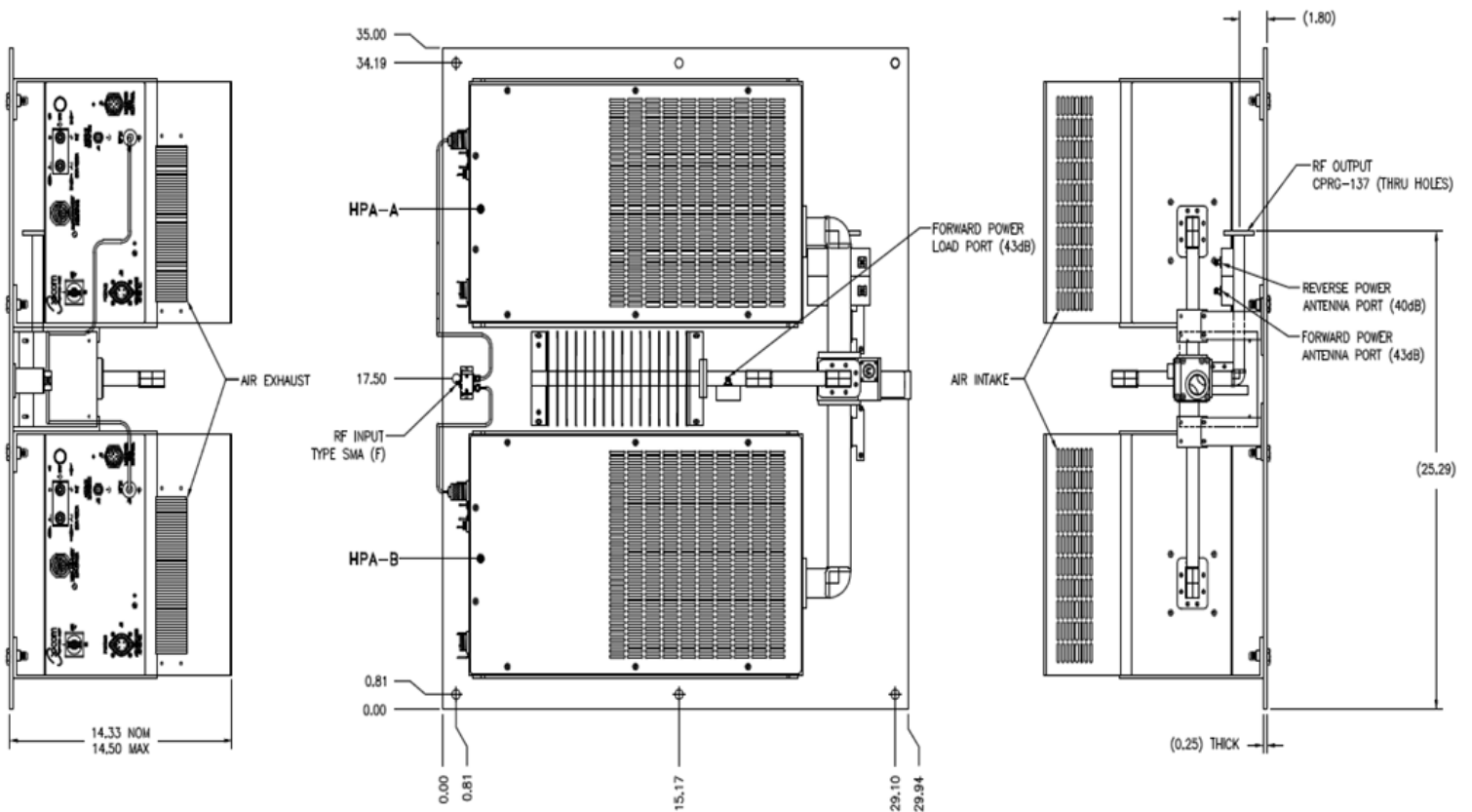
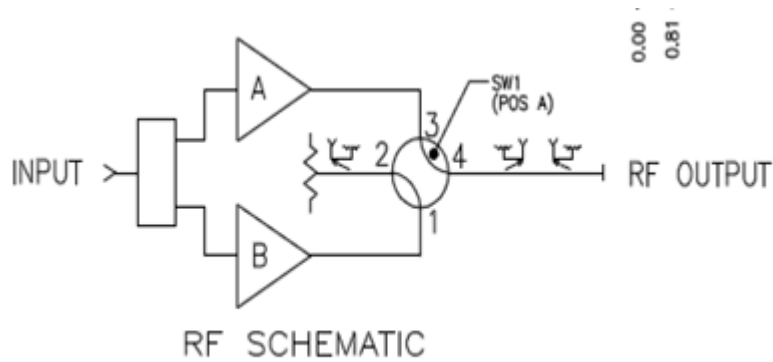

Order Examples: RBUC+TWTA-13.75-14.5-750W-ODU-1+1-n6
Description: (BUC + TWTA, 13.75-14.5GHz, 750W, Outdoor Unit, 1+1 Option)

SSPA Amplifier, C-Band, 5.850-6.725GHz, 400W- Redundant Ready



Features

- High RF output power
- Low spurious levels
- Various output power rating
- Easy installation & configuration
- RF output sample port
- Available for specific satellite brands
- Surge Protection
- Built-in Redundancy (1:1)
- Built in Isolator and Harmonic reject filter
- Reverse Power Detection

OPTION: Enhanced Monitoring and Control

SSPA offers M&C via RS232/485 and SNMP. It features full remote M&C through Windows using PC.

These include:

- TX level monitoring
- Temperature monitoring
- RF inhibit selection
- Gain control for rack mount SSPA
- Automatic fault identification & alarm
- SNMP

Order Examples: RSSPA-5.850-6.425-100W-g11

Description: SSPA Amplifier, 5.850-6.425GHz, 100W)

RSSPA-(1+1)-5.850-6.725-400W-g11 (Redundant version)

Specifications		Units
Frequency	5.850-6.725	GHz
Power	400	W (typ)
Output P1dB	56	dBm (typ)
Gain	57-62	dB
Power Consumption	2000	W
Gain Flatness over full BW	±1.0	dB max
Gain Slope over 36 MHz	±0.3	dB max
Gain Stability over Temperature	±2.0	dB (max)Outdoor
	±1.0	dB (max) Rack Mount
Gain Control Range	20	dB min step 0.1 dB (Rack Mount SSPA)
Input / Output VSWR	1.3:1	(Max)
Intermodulation	-25	dBc max (with 2 carriers, ±1MHz apart, 6dB backoff)
Harmonics (@P1dB)	-60	dBc max
Spurious (@P1dB)	-60	dBc max
Maximum Input Power	+ 10	dBm (without damage)
Display	24 x 2 LCD Display	(Rack Mount SSPA)
Power Supply	220 Vac or 110Vac (factory preset)	
RF Input	50 Ω N-Type Female	

RSSPA-C-5.850-6.725-400W-g11

Specifications may be subject to change

10/19/11

WORLD HQ: 1702L Meridian Ave. Suite 127, San Jose, Ca 95125, U.S.A.

Tel: (408) 266-7404

FAX: (408) 266-4483

WEB: www.raditek.com

E-mail: sales@raditek.com

SSPA Amplifier, C-Band, 5.850-6.725GHz, 400W- Redundant Ready

Specifications	Units	
RF Output	CPR137G (20W to 500W) / 50ohm N-Type Female (20W to 50W) Optional	
Monitor	SSPA Temperature Status Alarm RF Output Power RF Output monitor -30 dBc typical	
Control	Temperature threshold setting SSPA On/Off	
Protection	Over temperature SSPA shutdown	
Interface	RS232 / RS485 SNMP (Optional)	
Inbuilt Redundancy Control	Yes	
Operating Temperature	-40 to + 60 (Outdoor SSPA) 0 to + 50° (Rack Mount SSPA)	°C
Relative Humidity	Up to 95 (Non-Condensing)	%
Size	Indoor SSPA 19" rack , 5RU height (150W to 500W)	
Weight	37.0 (150W to 500W)	kg
Color	Grey	
Compliance Standards		
IEC 60950C	International Safety Standard for Information Technology Equipment	
ETSI EN 300 673	Electromagnetic Compatibility and RadioSpectrum Matters (ERM); ElectroMagnetic Compatibility (EMC) Standard for Very Small Aperture Terminal (VSAT)	
ETSI EN 301 489-1	Electromagnetic Compatibility and Radio Spectrum Matters (ERM); ElectroMagnetic Compatibility Standard for Radio Equipment and Services	

SSPA Amplifier, Ku-Band

(16/25/40/80, 100,150,200)W-ODU/(Rack), Redundant Ready



Indoor Model



Outdoor Model

Features

- High RF output power
- Low Spurious levels
- Various output power rating
- Easy installation and configuration
- RF out put sample port
- Available for specific satellite bands
- Surge protection
- Built-in Redundancy Controller (Rack Mount)

Enhanced Monitor and Control

Monitor and Control via RS232/485. It features full remote M&C through Windows using a PC.

These include

- TX level monitoring
- Temperature monitoring
- RF inhibit selection
- Gain control for rack mount SSPA
- Automatic fault identification & alarm
- SNMP

Order Example : RSSPA-14.0-14.5-80W-1+1-g11
(SSPA-14.0-14.5GHz, 80W-1+1)

Frequency Range

Standard	14.0-14.5	GHz
Offset	13.75-14.25	GHz
Extended	13.75-14.5	GHz
Low	13.0-13.25	GHz
Plan	12.75-13.25	GHz

Transmit

Power	Output P1dB (dB) min	Gain (dB)	Typ AC Power Consumption (VA)
16W	42	12-16	250
25W	44	14-18	300
40W	46	16-20	600
80W	49	19-23	800
100W	50	19-23	1200
150W	51.8	25-30	1800
200W	53	25-30	2800

SSPA Amplifier, Ku-Band (16/25/40/80, 100,150,200)W-ODU/(Rack), Redundant Ready

Specifications	Units	
Gain Flatness over full BW	±1.0	dB max
Gain Slope over 36 MHz	±0.3	dB max(Rack Mount)
	±0.5	dB max (Outdoor)
Gain Stability over Temperature	±1.0	dB (max) Rack Mount
	±2.0	dB max (Outdoor)
Gain Control Range	20	(Rack Mount SSPA)
Input VSWR	1.3:1	(Max)
Output VSWR	1.5:1	(Max)
Intermodulation	-25	dBc max (with 2 carriers, ±1MHz apart, 6dB backoff from output@P1dB)
Harmonics (@P1dB)	-60	dBc max
Spurious (@P1dB)	-60	dBc max
Maximum Input Power (without damage)	+ 10	dBm (Rack Mount)
	+33	dBm (Outdoor SSPA)
Display	24 x 2 LCD Display (Rack Mount SSPA)	
Power Supply	220 Vac or 110Vac (factory preset)	
Interface		
RF Input	50 Ω N-Type Female	
RF Output	WR75/G	
Monitor and Control		
Monitor	SSPA Temperature Status Alarm RF Output Power RF Output monitor -30 dBc	
Control	Temperature threshold setting SSPA On/Off	
Protection	Over temperature SSPA shutdown	
Interface	RS232 / RS485 SNMP (Optional)	
In built Redundancy Control	Yes	
Environmental		
Operating Temperature	-40 to + 60 (Outdoor SSPA)	°C
	0 to + 50° (Rack Mount SSPA)	
Mechanical		
Size	Outdoor	
	388L x 230W x 189H mm (16W, 25W, 40W)	
	434L x 420W x 232H mm (80W, 100W)	
Weight	TBD (150W, 200W)	
	15.0kg (16W, 25W)	
	20.0kg (40W)	
	28.0kg (80W, 100W)	
Color	35.0kg (150W, 200W)	
	White Powder Coat	
Mechanical		
Size	Rack Mount (Indoor)	
	19" rack , 3RU height (16W to 40W)	
Weight	19" rack , 5RU height (80W, 100W)	
	25.0 kg (16 to 40W)	
Color	34.0 kg (80W, 100W)	
	Grey	
Compliance Standards		
IEC 60950C	International Safety Standard for Information Technology Equipment	

SSPA Amplifier, Ku-Band (16/25/40/80, 100,150,200)W-ODU/(Rack), Redundant Ready

ETSI EN 300 673	Electromagnetic Compatibility and RadioSpectrum Matters (ERM); ElectroMagnetic Compatibility (EMC) Standard for Very Small Aperture Terminal (VSAT)
ETSI EN 301 489-1	Electromagnetic Compatibility and Radio Spectrum Matters (ERM); ElectroMagnetic Compatibility Standard for Radio Equipment and Services

Additional information on Rack Mount Requirements for 100W Model

100W Ku Band SSPA is 5 RU.

Transmit side has an internal controller so no additional space required.

For a system including an Up Converter and SSPA 1:1 redundant system
2 x 1U for the Up Converters
and 2 x 5U for the SSPAs,
for a total of 12 RU.

Receive side needs a separate controller which is 1RU in height.

2 x 1 RU for the Down Converters
and 1RU for the Controller
for a total of 3 RU.



TWT Amplifier
 6-9GHz, 2kW, 4% Duty
 RTWTA-6-9-2kW-4%-w9



Frequency Range:	6-9 GHz
Output power PSat.	63 dBm nominal
Input power	0 dBm for rated output power
Duty	4% maximum
RF Level Adjustment Control	20 dB (min)
Spurious for 0-250Hz	55 dBc max.
Spurious for >250Hz	60 dBc max.
Output VSWR protection	Refl. Pwr 100%
Output pulse video sample	+10 mV/kW into 50Ω
Output Pulse sample	-40 dB
Interstage Power sample	-20 dB
Input Power sample	-20 dB
MODULATION	
Pulse width	0.1 to 100µs
Pulse repetition rate	0-100 KHz
Rise and fall time	15ns max.
Droop	0.01 dB/ µs
Pulse jitter	±2ns
Video/RF delay	300ns max.
ELECTRICAL	
Primary Input Power Mains	115 ±10%, single phase. 60Hz
Primary Power Consumption	2.1kVA max.
Elapsed Time Meter	00,000.00 Hours
Modulation input pulse	+5V TTL
Digital Interface	RS-232
MECHANICAL	
Front panel Std RETMA	1/8 " thick w slotted mtg holes
Dimensions:	19" x 8.75" x 28" deep (Rack)
Weight:	85 Pounds typical
Finish	Front: Anodized Black Chassis: Gold Alodine
Cooling	Self Contained Forced air
CONNECTORS: (RF - can be located front or rear panel)	
Input: on rear panel	Coax, Type-N (f)
Output: on rear panel	Waveguide WRD-475 or "N (F)"
External. WG to Coax	WRD-475 to Type "NF"
RF Sample front panel	Co-ax, Type-NF
Modulation Input Pulse	Co-ax, Type BNFC

RF output video pulse	Co-ax, Type BNFC (front panel)
RS232	DB25 F (rear panel)
IEEE-488 (option)	GPIOB, rear panel
Ethernet (option)	RJ-45
Primary Power Input	NEMA L5-20, three wire
ENVIRONMENTAL	
Temperature: Operating	0°C to +50°C (derate 10 °C per 10,000 feet altitude)
Storage:	-30°C to +60°C
Humidity:	0-95% non condensing
Altitude	To 10,000 feet (-30 to 60°C)
MONITOR & CONTROL	
Computer Interface:	IEEE-488 (GPIOB) rear panel (optional) Ethernet RJ45 rear panel (optional) RS 232 DB25 rear panel
Conditions monitored and interlocked.	
VSWR	
Body Voltage	xx.xx KV
Body current	xx.xx mA
Heater Voltage	x.xx V
Heater Current	x.xx A
Grid bias voltage	xxx.xx V
Grid Pulse amplitude	xxx.xx V
Lid Access interlock	Fault
Over temperature	Fault
PRF limit	Fault
Pulse width limit	Fault
Pulse received	Yes/No

RS 232 interface allows remote operation, monitor, control; and adjustment. IEEE-488 Optional provides ability to remotely operate monitor and control operation of amplifier. Any fault condition latches the information. Ethernet is also available. Software provided to operate with MS Windows.

The following parameters. have high and low limits that are factory adjustable:

Cathode Voltage, Body Current, Heater Voltage, Heater current, Grid bias voltage. Grid Pulse Amplitude. PRF limits. Pulse width Limit.



LNB C-Band, PLL,
Nf-Internal Reference (\pm xKHz Stability)

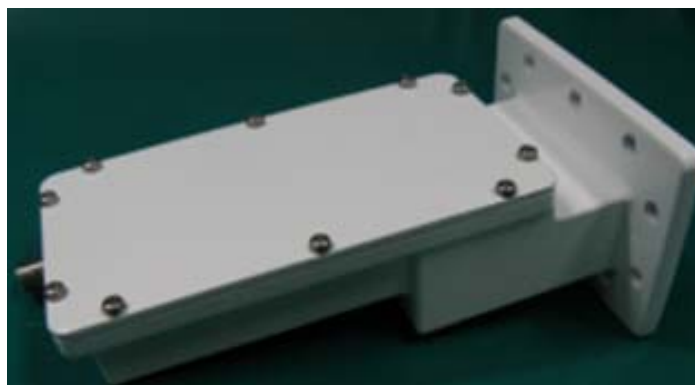

Order Examples: RLNB-C(4.5-4.8)-PLL-Nf-IR \pm 25K-w13

Description: (LNB, C (4.5-4.8GHz), PLL, N female, Internal Reference \pm 25KHz Stability)

Input Freq.(GHz)	Output Freq.(MHz)	LO Freq.	Stability
4.5 - 4.8	965 – 1265	5.76 GHz	+/- 5 KHz
4.5 - 4.8	965 – 1265	5.76 GHz	+/- 10 KHz
4.5 - 4.8	965 - 1265	5.76 GHz	+/- 25 KHz

Specifications		Units
Noise temperature (@+25°C)	30 max.	°K
Input VSWR	2.5 : 1 max.	
Image rejection	45 min.	dBc
Conversion gain	65 (typ). 55 (min). 70 (max).	dB
Output VSWR	2.5 : 1 max.	
Gain flatness	4 (max).	dBp-p
Gain ripple (@per 27 MHz segment)	+/- 0.5 (max).	dB
1dB gain compression point	+3 (min)	dBm
Output impedance	75/ 50	Ohms
Leakage (@ input port)	-45 (max.)	dBm
Phase noise	-65	dBc/Hz @1KHz offset
	-80	dBc/Hz @10KHz offset
	-95	dBc/Hz @100KHz offset
Power supply	+12 to +24	V DC
Required current	250 (max.)	mA
Operating temperature	-40 to +60	°C
Storage temperature	-40 to +80	°C
Relative humidity	0 to 95	% RH
Input waveguide flange	WR- 229	
IF Output Connector	F-Type female 75 Ohm N-Type female 50 Ohm	
Weight	575 g	

LNB C-Band, PLL/DRO, N female,-Internal Reference (\pm xKHz Stability)

Outline Drawing

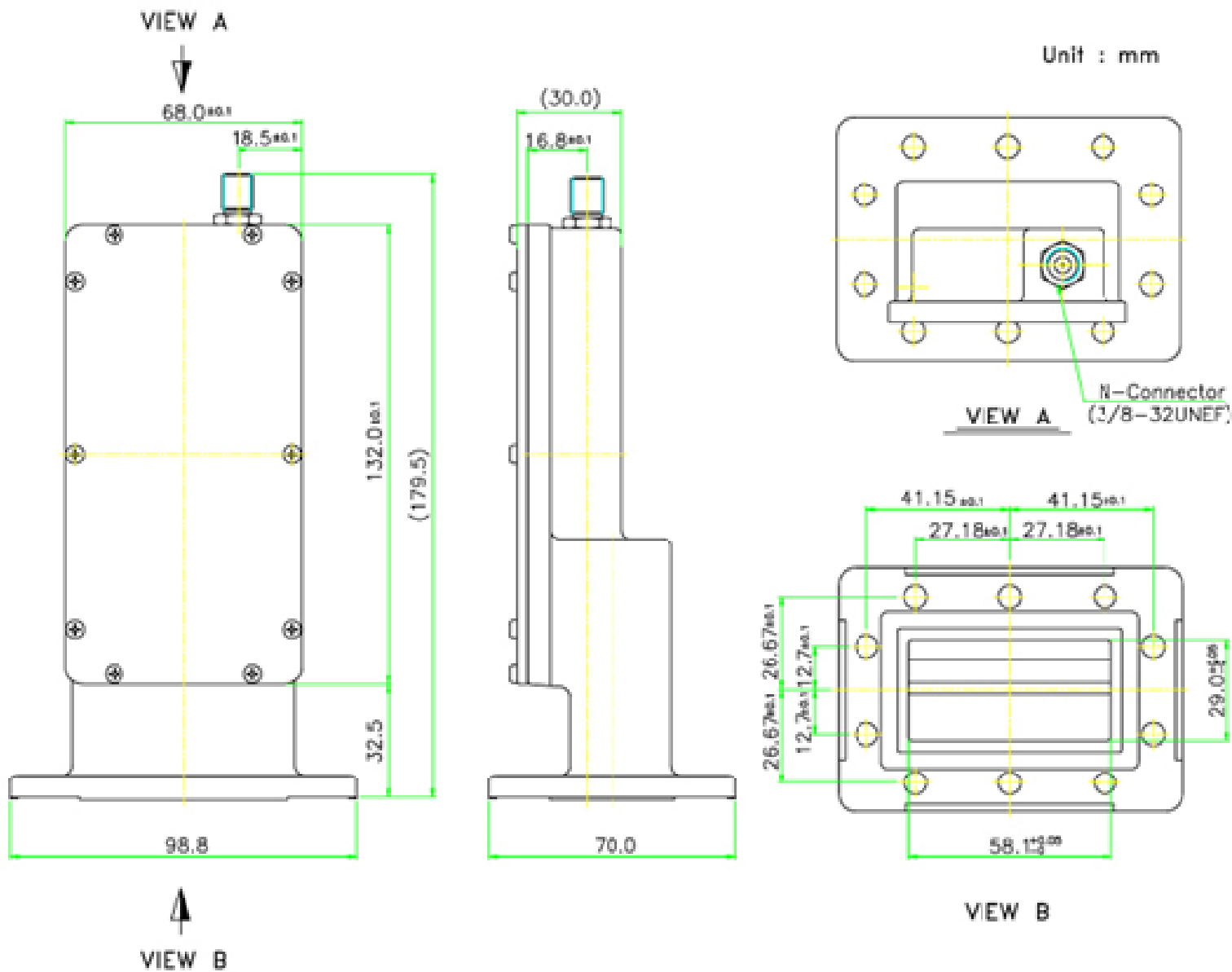



LNB,
Ka-Band to L-Band, F female, DRO

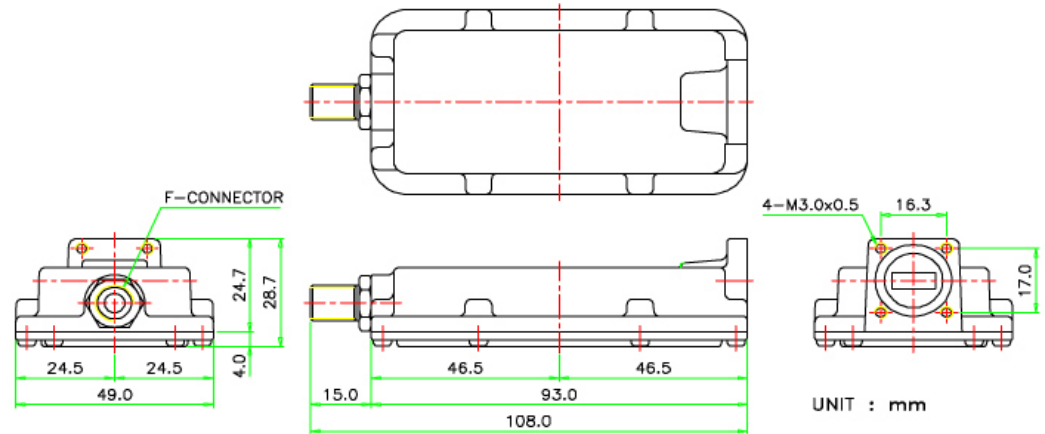

Order Examples: RLNB-19.2-19.85-L-Ff-DRO-D-w13

Description: (LNB, 19.2-19.85GHz to 950-1600MHz, F female, DRO, D Model)

	Input Frequency (GHz)	Output Frequency (MHz)	LO Frequency (GHz)
A	18.0 ~ 18.65	950 ~ 1600	17.05
B	18.127 ~ 18.777	950 ~ 1600	17.177
C	18.2 ~ 18.85	950 ~ 1600	17.25
D	19.2 ~ 19.85	950 ~ 1600	18.25
E	20.2 ~ 20.85	950 ~ 1600	19.25
F	20.2 ~ 21.85	950 ~ 1600	20.25

Specifications		Units
Noise figure (@+25°C	1.6 to-2.0	GHz
Input VSWR	3.0:1	typ
Image rejection	40	dBc min.
Conversion gain	55	dB typ
Output VSWR	2:1 max	dBc/Hz
Gain flatness	6	dBp p max
Gain ripple(@per channel)	+/-0.75	dB max
1dB gain compression point	0	dBm max
Output impedance	75	ohms
Leakage (@ input port)	-60	dBm max
L.O Stability (over temp)	+/-2.0	MHz
Phase noise	+75dBc/Hz	@10KHz
Power Supply	+12 to+24V	°DC
Required current	150	Ma max
Operating temperature	-30 ~60	°C
Storage temperature	-40~80	°C
Relative humidity	0% to 95%	RH
Input waveguide flange	WR-42	
IF output connector	F-type female	
Weight	162	g